

**U.S.
INSTALLATION
INSTRUCTIONS,
WARRANTY
AND
MAINTENANCE
GUIDE**

Selkirk Corporation
5030 Corporate Exchange Blvd., Grand Rapids, MI 49512
Toll Free: 1.800.433.6341
www.selkirkcorp.com





**INSTALLATION
INSTRUCTIONS
&
MAINTENANCE
GUIDE**

FACTORY BUILT TYPE HT INSULATED CHIMNEY



Listed

**Tested to
UL103**

**A MAJOR CAUSE OF CHIMNEY RELATED FIRES
IS FAILURE TO MAINTAIN REQUIRED CLEARANCES
(AIR SPACES) TO COMBUSTIBLE MATERIALS.**

**IT IS OF THE UTMOST IMPORTANCE THAT THIS
CHIMNEY BE INSTALLED ONLY IN ACCORDANCE
WITH THESE INSTRUCTIONS.**

**PLEASE READ ALL INSTRUCTIONS BEFORE BEGINNING YOUR INSTALLATION.
FAILURE TO INSTALL THIS SYSTEM IN ACCORDANCE WITH THESE
INSTRUCTIONS WILL VOID THE CONDITIONS OF CERTIFICATION AND THE
MANUFACTURERS WARRANTY .
KEEP THESE INSTRUCTIONS IN A SAFE PLACE FOR FUTURE REFERENCE.**

Selkirk Corporation
5030 Corporate Exchange Blvd., Grand Rapids, MI 49512
Toll Free: 1.800.433.6341
www.selkirkcorp.com



TABLE OF CONTENTS

TYPE OF APPLIANCES	4
PRE-INSTALLATION GUIDELINES	4
TOOLS	4
FRAMING DETAILS	5
CEILING SUPPORT INSTALLATION	5
STOVE PIPE ADAPTOR	5 - 6
ATTIC INSULATION SHIELD INSTALLATION	6
FIRESTOP JOIST SHIELD INSTALLATION	7
ELBOW INSTALLATION	7
ADJUSTABLE WALL SUPPORT INSTALLATION	8 - 9
ADJUSTABLE INTERMEDIATE WALL SUPPORT	9
CATHEDRAL CEILING SUPPORT INSTALLATION	9 - 10
RAFTER RADIATION SHIELD INSTALLATION	10
ROOF SUPPORT INSTALLATION	10 - 11
ROOF FLASHING INSTALLATION	11 - 12
ROOF GUY INSTALLATION	12 - 13
MAINTENANCE AND CLEANING OF CHIMNEY	14
CHART 1 - OFFSET CHIMNEY INSTALLATION	15
CHART 2 - CHIMNEY HEIGHT ABOVE THE ROOF	16
CHART 3 - CONNECTOR PIPE CLEARANCES - CATHEDRAL SUPPORT	16
REPLACEMENT PARTS LIST	17
INSTALLATION RECORD & PRODUCT REGISTRATION	18

TYPE OF APPLIANCES

Your SuperVent/SuperPro chimney is intended for venting gas, liquid, or solid fuel fired residential type appliances and building heating appliances or as defined in the NFPA 211, in which the maximum continuous flue gas temperatures do not exceed 1000°F. It has been tested and approved to withstand temperatures of up to 2100°F for three ten minute intervals.

PRE-INSTALLATION GUIDELINES

If you choose to have your product professionally installed, we recommend these products be installed by professionals who are certified in the U. S. by NFI (National Fireplace Institute).

Your SuperVent/SuperPro chimney and connecting stove pipe diameter should be sized in accordance with the appliance manufacturer's recommendations.

Plan the installation of your appliance and chimney in such a way that both your chimney and your stove pipe run is as short and straight as possible. By having too long and or multiple bend installations you can reduce system draft which can affect the operation, and or performance of your appliance and or chimney system. The chimney should be located within the building so as to avoid cutting or altering load bearing members such as joists, rafters, studs, etc. If you require to cut or alter an existing load bearing member, special reframing methods are required which often include doubling of adjacent members. If such a case arises, contact your local Building Code Official regarding local regulations and proper installation methods.

Sections of the SuperVent/SuperPro chimney which pass through accessible areas of the building such as through closets, storage areas, occupied spaces or any place where the surface of the chimney could be contacted by persons or combustible materials must be enclosed in a chase to avoid personal contact and damage to the chimney. The chase may be fabricated using standard building materials. Drywall mounted on 2" x 4" studs is typically used in this situation. The space between the outer wall of the chimney and the enclosure must be a least a minimum of 2 inches.

MAINTAIN A 2" MINIMUM AIR SPACE CLEARANCE BETWEEN INSULATED CHIMNEY SECTIONS AND COMBUSTIBLE MATERIALS.

WARNING: DO NOT PLACE ANY INSULATING MATERIALS OR RUN ANY ELECTRICAL WIRING WITHIN THE REQUIRED AIR CLEARANCE SPACE SURROUNDING THE CHIMNEY.

Before beginning the installation ensure that you obtain any necessary building permits, and that your installation will conform with all federal and municipal building code requirements.

CONTACT LOCAL BUILDING OR FIRE OFFICIALS ABOUT RESTRICTIONS AND INSTALLATION INSPECTION IN YOUR AREA.

The National Fire Protection Association Standard 211 states: Factory-built chimneys that pass through floors of buildings requiring the protection of vertical opening shall be enclosed with approved walls having a fire resistance rating of not less than 1 hour where such chimneys are located in a building less than four stories in height, and not less than 2 hours where such chimneys are located in a building four or more stories in height.

WEAR SAFETY GLOVES WHEN HANDLING SHEET METAL PARTS WITH SHARP EDGES

Authorities require that the chimney extend not less than 3 feet above the highest point where it passes through the roof of a building and not less than 2 feet above any portion of the building within 10 feet (see figure 1). See Chart 2 for Chimney Height Above the Roof on page 16 of these instructions.

FIGURE 1

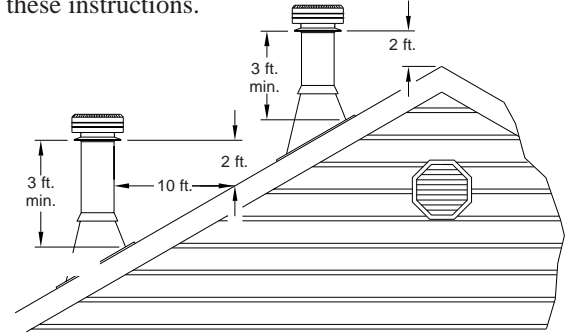

The use of Locking Bands at all chimney joints is recommended for added safety and stability when exposed to high winds and as a precaution against accidental unlocking of lengths when the system is inspected and swept.

The ideal location for your chimney system is within the building envelope. In cold climates, the use of external chimneys may result in operational problems such as poor draft, excessive condensation of combustion products and rapid accumulation of creosote. Under these circumstances, the installation of the chimney within the building is strongly recommended.

If the chimney must be installed on an exterior wall it is recommended that the chimney be enclosed below the roof line to protect the chimney from cold outdoor temperatures, this may help reduce condensation, creosote formation and enhance draft. Provide an access door by the Tee Plug for chimney inspection and cleaning. The exterior enclosure may be insulated, maintaining the required minimum air space clearance of 2" to any part of the chimney. Consult local building codes for cold climate application.

Do not install the chimney directly at the outlet of the appliance. Interconnecting stove pipe is required unless the appliance is specifically approved for that type of installation.

Use only with an appliance listed by a recognized testing authority such as Underwriters Laboratories Inc., Underwriters Laboratories of Canada or Intertek Testing Services.

The flue diameter of gas or oil fired appliances should comply with the appropriate NFPA or ANSI Installation Codes; NFPA 54, ANSI Z223.1, and NFPA 31.

YOUR CHIMNEY HAS BEEN TESTED, AND LISTED USING ALL OF THE SUPPORTS, SHIELDS, ETC., DESCRIBED HEREIN. DELETION OR MODIFICATION OF ANY OF THE REQUIRED PARTS OR MATERIALS MAY SERIOUSLY IMPAIR THE SAFETY OF YOUR INSTALLATION, AND VOID THE CERTIFICATION AND OR WARRANTY OF THIS CHIMNEY

TOOLS

Your SuperVent/SuperPro chimney system is designed for installation using standard building materials and procedures. The following tools/equipment may be required as well as some others depending on the location and structure in which the chimney is to be installed:

- safety gloves
- safety goggles
- hammer and nails
- tin snips
- tape measure
- screwdriver and pliers
- plumb line and level
- square
- keyhole saw or power jig saw
- caulking gun

FRAMING DETAILS:

Plan your installation carefully. If possible, position the stove so that the flue outlet is between joists or rafters. Drop a plumb line to the center of the flue outlet and mark this center point on the ceiling. Lay out and frame in all openings ensuring the specified 2" clearance to combustibles is maintained. Refer to Table 1 and applicable Tables for framing dimensions and mark the appropriate cutting lines around the center point. All openings should be square (all four sides), plumb and in perfect alignment with each other (see figure 2). For sloping roofs (cathedral/vaulted ceiling), ensure that the framing dimension is measured in the horizontal plane (see figure 3).

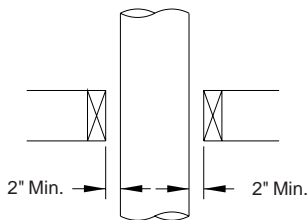

FIGURE 2
Typical Joist Framing

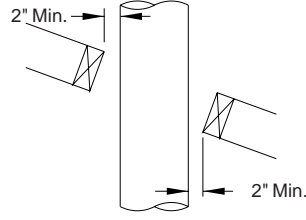

FIGURE 3
Typical Roof Joist Framing

TABLE 1 Framing Dimensions			
Chimney Flue Diameter	*Decorator Ceiling Support	* Wall (Support) Thimble	All Other Framing
5"	12 ³ / ₈ x 12 ³ / ₈	14 x 14	11 x 11
6"	12 ³ / ₈ x 12 ³ / ₈	14 x 14	12 x 12
7"	13 ³ / ₈ x 13 ³ / ₈	14 x 14	13 x 13
8"	14 ³ / ₈ x 14 ³ / ₈	14 x 14	14 x 14

Note: *When cutting the inside "finished" surface of your wall or ceiling cut a "round hole" for the framing dimension and not a square hole; i.e.: 14" x 14" would be a 14" round opening.

INSTALLATION PROCEDURES:

CEILING SUPPORT

To complete a proper Decorator Ceiling Support installation, the following parts will or may be required:

- Decorator Ceiling Support (DCS): Required when supporting a chimney through a flat level ceiling.
- Stove Pipe Adaptor (ASE): Transition from the chimney to flue pipe.
- Attic Insulation Shield (AIS): Required where a chimney passes from a lower living space into an unoccupied attic space.
- Firestop Joist Shield (FRS): Required where a chimney passes from a lower living space into an upper living space or occupied attic space.
- Roof Flashing Assembly (including Storm Collar): Required when the chimney penetrates a roof.
- Rafter Radiation Shield: Required when the chimney is enclosed immediately below the roof.
- Suitable lengths of Chimney: The chimney diameter (ID) should be sized to suit the appliance.
- 15° or 30° Elbow Kit: To avoid cutting of joists and clear other obstructions. Kit includes: 2 Elbows, 1 Offset Support and 4 Locking Bands.
- Rain Cap: Standard or Deluxe model.

The SuperVent/SuperPro Ceiling Support will support up to 50 feet of chimney sections, all of which must be installed above the support. Figures 4 & 7 show the 2 most common types of Ceiling Support Installation. Frame (on all 4 sides) a level square opening to the dimensions specified in the Framing Dimension Table 1.

Slide the Trim Ring onto the Ceiling Support and slide the assembly into the framed opening from below. Ensure that the finishing ring is flush with the underside of the ceiling and the assembly is level and plumb. Secure the ceiling support in place using at least three (3) 8-penny (2-1/2") nails through each of the 4 straps or through the 12 prepunched holes in the support. You may substitute in lieu of nails 12 - #8 x 2" wood screws.

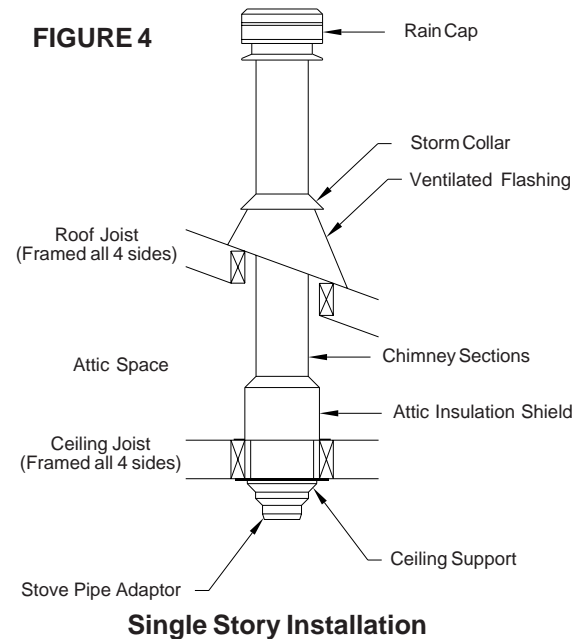

STOVE PIPE ADAPTOR

The Stove Pipe Adaptor (ASE) is installed by twist-locking it into the bottom end (female end) of the first Chimney Section that enters the Ceiling Support. Do not install an elbow in the Ceiling Support. Make sure that the male coupler of the insulated Chimney Length is pointing upwards as indicated by the arrow on the chimney label. Lower the assembly down into the Decorator Ceiling Support ensuring that the Stovepipe Adaptor sleeve is protruding through the support and into the living space (see Figure 5).

The crimped end (stub) of the Stove Pipe Adaptor is intended to fit inside of the flue pipe from a solid fuel appliance, thus preventing condensate drips at the chimney connection. Install inter-connecting

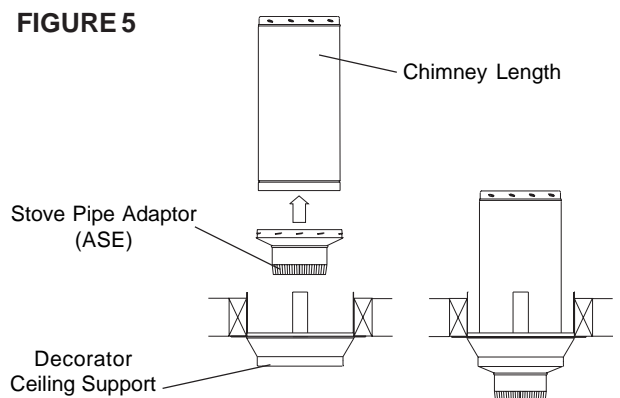

flue pipe following the appliance manufacturer's installation instructions and appropriate building code requirements keeping in mind that the flue pipe run should be as short and straight as practicable. Generally, for a wood burning appliance installation, an 18" minimum clearance to combustibles must be maintained for a single wall flue pipe. The exception to this is a double wall stove pipe, such as Selkirk's **Model DSP** which can be installed at reduced clearances of 6" to combustibles. See separate installation instructions for more details.

Install additional chimney sections and lock together by turning clockwise until the two sections lock together snugly. Install a Locking Band to secure the two chimney sections. Continue adding chimney lengths until a height of about 2ft. below the next ceiling level is achieved.

NOTE: When a suspended ceiling is encountered a Cathedral Ceiling Support Box is to be installed. Secure the Cathedral Ceiling Support Box to the floor/ceiling joist framed on all 4 sides. The box must extend a minimum of 1" into the room below the suspended ceiling. Chimney Length is to protrude a minimum of 3" below support. Trim angles must be installed.

ATTIC INSULATION SHIELD

An Attic Insulation Shield (AIS) must be installed where the chimney enters an attic space. An Attic Insulation Shield is to keep insulation from coming into contact with the chimney and will allow a depth of insulation of 10 inches plus the depth of the ceiling joist. Where height restrictions will not permit the use of the Attic Insulation Shield, an enclosure from the attic joist to the roof joist will be sufficient. All chimney enclosures must maintain the required minimum air space clearance of 2" to the chimney. When enclosing the chimney below the roof line, a Rafter Radiation Shield (RRS) must be installed at the roof level and a Firestop Joist Shield (FRS) at the ceiling level.

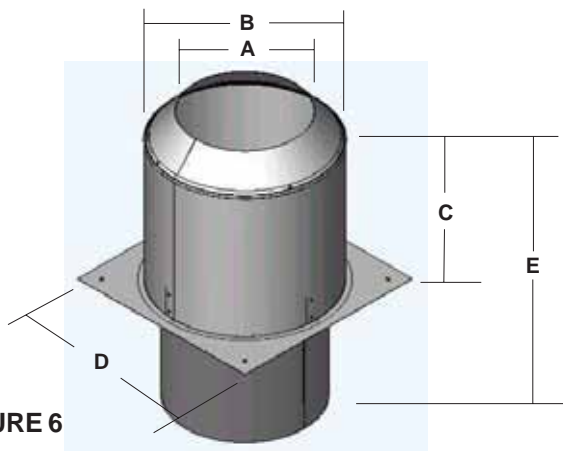

FIGURE 6

DIAMETER OF CHIMNEY	5"	6"	7"	8"
FRAMED OPENING	11 x 11	12 x 12	13 x 13	14 x 14
"A" DIM.	7 -1/4"	8 -1/4"	9 -1/4"	10 -1/4"
"B" DIM.	11"	12"	13"	14"
"C" DIM.	10"	10"	10"	10"
"D" DIM.	13"	14"	15"	16"
"E" DIM.	18 -1/2"	18 -1/2"	18 -1/2"	18 -1/2"

For proper installation, the attic opening must be fully framed at 2 inches of clearance to the chimney pipe with framing material of the same dimension as the ceiling joists and as per Framing Dimension Table 2. The tabs on the plate of the AIS are inserted in the framed opening around the chimney. Nail the AIS base to the framing with at least 2 per side, using 2d (1") spiral nails or 1" x #8 wood screws.

NOTE: To reduce cold air infiltration into the dwelling you can install the optional Universal Shielding Insulation (JUSI) into the Attic Insulation Shield. See separate installation instructions packaged with the JUSI.

When an Attic Insulation Shield is required above the Ceiling Support into an attic as shown in Figure 4, ensure that the base of the shield is flush with the top of the joist framing and nail in place. The telescoping portion of the AIS will eliminate the need to trim the bottom when installed immediately above the ceiling support. When fully extended, the AIS will provide joist shielding when installed in a 2 story main floor or basement application (see Figures 7 & 8).

If insulation is blown in and adheres to the chimney pipe, it must be brushed off to eliminate any possible contact of this material with the chimney surface.

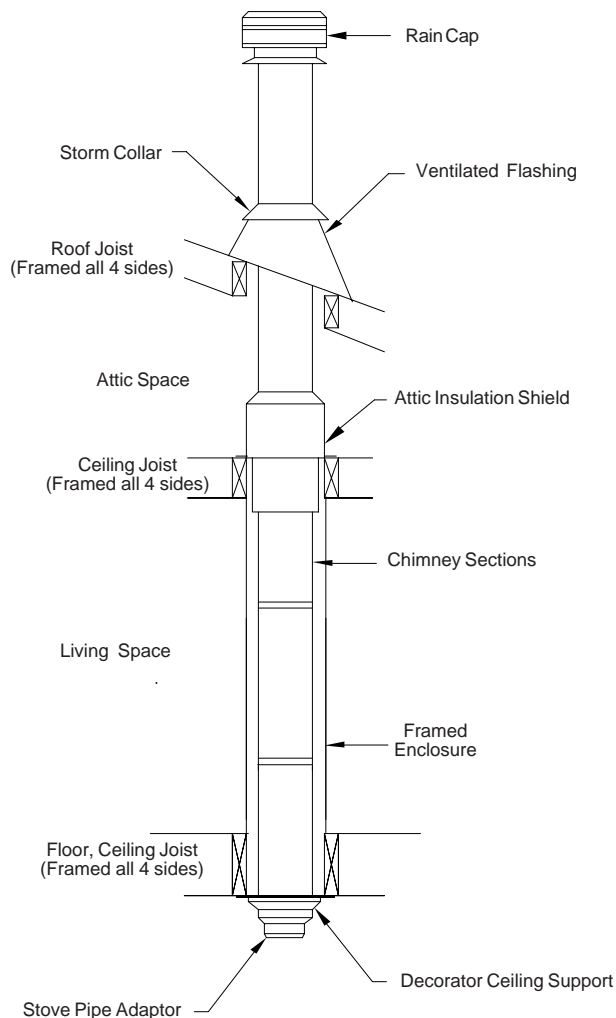

FIGURE 7

Two Story Main Floor Installation

FIRESTOP JOIST SHIELD

A Firestop Joist Shield (FRS) must be installed where the chimney passes from one living space to another living space, as shown in figure 8. It is designed to provide proper firestopping between floors and to keep direct radiation from the chimney away from the joist framing.

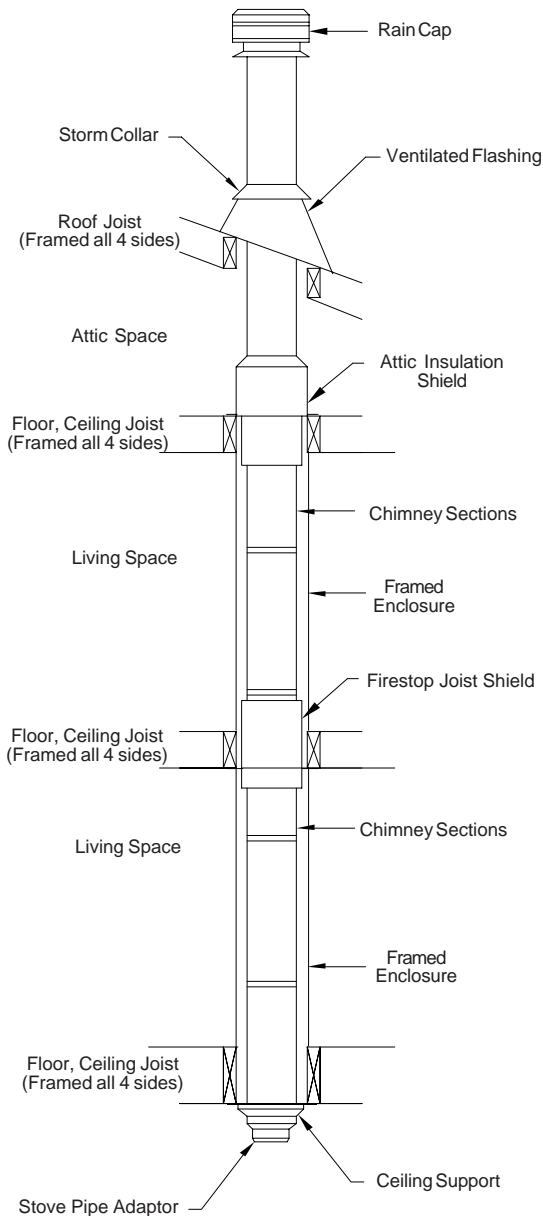

FIGURE 8

Two Story Basement Installation

Install the Firestop Joist Shield (FRS) from below the joist framing and nail in place using 1" spiral nails. Ensure no insulation is within the 2" air space clearance around the chimney. This includes the air spaces between the Firestop Joist Shield (FRS) and the joist framing.

When the chimney is enclosed in the attic area, a Firestop Joist Shield (FRS) must be installed at the ceiling level. If the base of the Firestop Joist Shield (FRS) does not fit flush with the ceiling frame, measure the distance that the base is sitting below the framing and trim that amount off of the top of the FRS before securing into place.

ELBOW INSTALLATION

One pair of (two) 15° or 30° Elbows may be used in an interior installation to provide an offset in order to avoid cutting of joists and to clear other obstructions. Each Elbow support will support 15 feet of chimney and the maximum length of chimney allowed between elbows is 6 feet.

Forty-five-degrees (45°) Elbows may be used only with oil or gas appliances. See Chart 1 - Offset Chimney Installation on page 15 in these instructions for details.

The female end of Elbows are **not** embossed. This allows 360° rotation and ensures the proper alignment of the chimney system is maintained. Locking Bands must be installed at all chimney joints forming an offset.

Install the insulated offset Elbow on the vertical chimney Length and position the elbow in the required direction. Fasten the Elbow to the chimney Length with the supplied Locking Band.

Place the required offset chimney Length(s) as per the Offset Chart for appropriate Length(s). Turn it clockwise to lock it in place and fasten in place with the supplied Locking Band.

Install the remaining Offset Elbow to turn the chimney back to the vertical position and fasten in place with the supplied Locking Band.

During installation provide supplementary support for the offset section to avoid undue stress on connected elbows.

Install an Elbow Support on the first Length just above the highest Elbow. Attach the Support Band to the chimney with 4 of the nuts and bolts, and then install the four stainless steel sheet metal screws through the pre-punched holes. Attach the Support Straps to the Support Band assembly and nail the Support Straps to the framing using 6d (2") nails or #8 x 1-1/2" wood screws (see figure 9).

Never install an Elbow in a joist area. Chimney Lengths must pass vertically through framed joist areas.

FIGURE 9

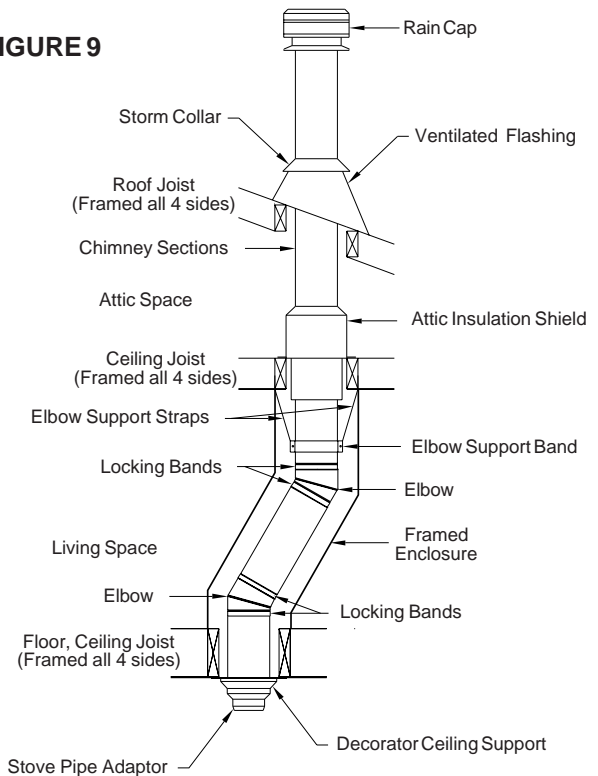

Offset (Elbow) Installation

ADJUSTABLE WALL SUPPORT

As previously mentioned, the ideal location for your chimney system is within the building envelope. A Wall Support installation is required when the above mentioned location is not possible.

To complete a proper Wall Support installation, the following parts will or may be required:

- Adjustable Wall Support (AWS): Intended for a through-the-wall installation where the chimney has a horizontal connection.
- Stove Pipe Adaptor (ASE): Transition from chimney to flue pipe.
- Insulated Tee (ITS): Allowing an horizontal connection to the chimney.
- Roof Flashing Assembly: Required when the chimney penetrates a roof or a roof overhang.
- Rafter Radiation Shield (RRS): Required when the chimney is enclosed immediately below the roof.
- Wall Band (WB): Required to provide lateral support to chimney.
- Suitable lengths of chimney: The chimney diameter should be sized to suit the appliance.
- Wall Thimble (WT): - Required to pass through a combustible wall.
- Rain Cap: Standard or Deluxe model.
- Universal Shielding Insulation (JUSI): To stop cold air infiltration.

NOTE: NEVER OFFSET AN EXTERIOR CHIMNEY.

The SuperVent/SuperPro Adjustable Wall Support will support up to 38 feet of chimney, all of which must be above the support with the exception of the 1 foot cleanout section and/or the Insulated Tee Plug, which is installed below the support.

If the total chimney height exceeds the Adjustable Wall Support limitations, an Adjustable Intermediate Wall Support must be installed. The use of an AIWS will support an additional 38 feet of chimney.

FIGURE 10

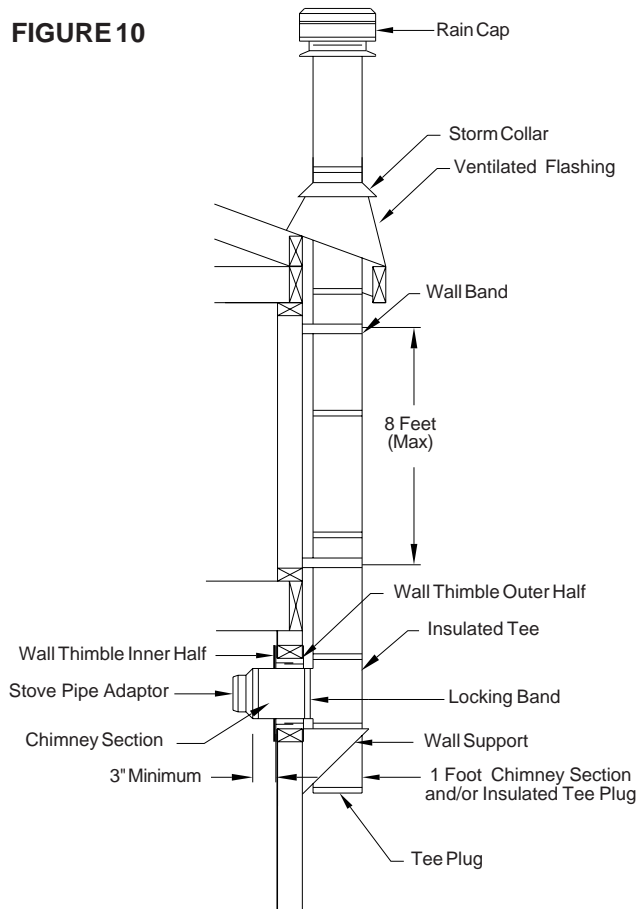

Wall Support Installation

A Wall Thimble will be required when passing through a combustible wall and will accommodate a wall thickness up to 8-3/4" (see Figure 11).

After framing in your opening to the dimensions specified (see Framing Dimensions Table 1) on page 5, install the exterior outer half (with the unfinished square plate) of the wall thimble into the outside wall opening. Secure in place with appropriate fasteners through the pre-punched holes.

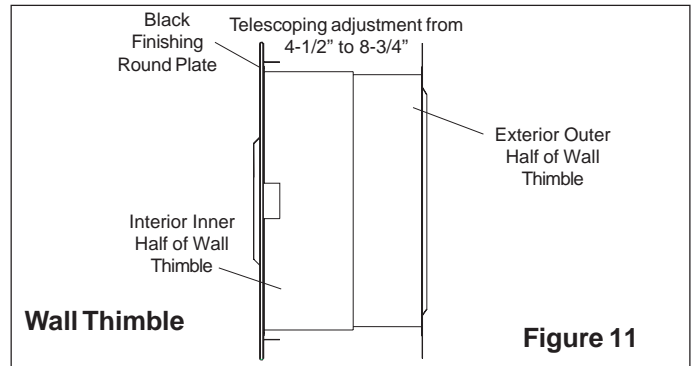

Figure 11

Install the interior inner half (with round plate and tabs) of the wall thimble into the inside wall opening, ensuring that the shield slides over the shield of the exterior outer half (see Figure 11). Once in place and flush against the wall, install the black finishing trim plate (round black plate) onto the inside wall surface and fasten in place with appropriate fasteners through the four pre-punched holes.

For a non combustible wall, cut a hole 3/16" greater than the outside diameter of the chimney.

NOTE: To reduce cold air infiltration into the dwelling you can install the optional Universal Shielding Insulation (JUSI) into the Attic Insulation Shield. See separate installation instructions packaged with the JUSI.

Assemble the Wall Support (Figure 12) by attaching the 2 side brackets to the support plate with the supplied hardware. Ensure that the female coupler attached to the underside of the support plate is facing down. For an adjustment of the support plate, align the fixed holes on the support plate with the elongated holes on the side brackets.

Install an appropriate Insulated Chimney Length such as a one foot (or longer if required-not to exceed 24 inch) Length of Insulated Chimney to the horizontal branch of the Insulated Tee.

NOTE: THE CHIMNEY MUST EXTEND AT LEAST 3" (75 MM) INTO THE LIVING SPACE WHERE THE STOVE PIPE CONNECTOR WILL BE ATTACHED TO THE CHIMNEY BRANCH.

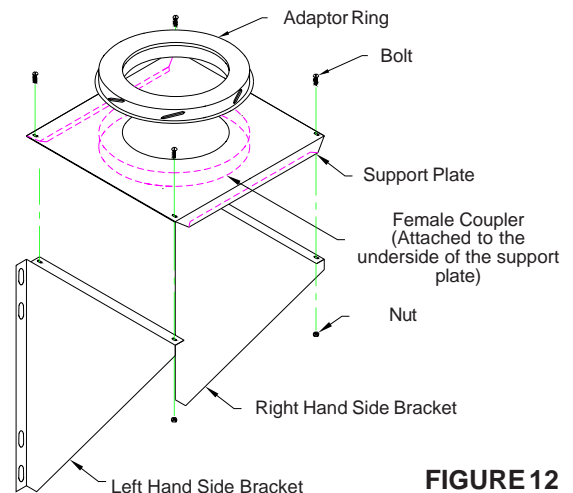

FIGURE 12

Lock securely into the Tee branch by twisting clockwise. A Locking Band must then be installed to secure the connection. Make sure the nut and bolt are facing down to prevent any water from collecting in the Locking Band. The Tee branch extension must protrude a minimum of 3" into the room.

NOTE: Ensure that you have set aside the Tee Plug, if not, do so now as you will require it later.

From outside the building, slide the assembly (Chimney Length installed on the Tee branch) through the Wall Thimble ensuring the male coupling on the Tee is facing upward. Insert and twist lock the Adaptor Ring in the female coupler of the Insulated Tee (bottom of Tee). Place the assembled Wall Support against the wall (support plate facing up) directly below the Tee. Slide the Wall Support up to the Tee ensuring that the stub of the Adaptor Ring (Figure 12) is inserted into the opening of the Support Plate.

Prior to securing ensure that the Insulated Tee assembly is plumb, level and sitting flush on the Support Plate. Secure to the wall through the pre-punched holes located on each side of the Wall Support Brackets using eight (8) #14 x 1/2" hex head lag screws or #10 x 2" wood screws. Make sure they go into solid bracing. If the support is properly positioned, these lag bolts will go into wall studs placed on 16" centers. For concrete block or poured foundation use suitable fasteners.

Use a non-hardening high-temperature silicone sealant (500°F) to seal around the horizontal chimney length where it enters through the exterior of the Wall Thimble or the concrete wall.

Twist lock a 12" section into the Female Coupler beneath the Support Plate. Twist lock the Tee Plug into the bottom of the section. You can substitute an Insulated Tee Plug (ITP) for the 12" section.

Chimney Lengths above the Insulated Tee are simply stacked on and locked with a 1/8 clockwise turn.

For lateral stability of the chimney above the Wall Support, a Wall Band must be installed along an outside wall. Install the first Wall Band midway up the first Chimney Length above the Insulated Tee. Any additional Wall Bands are to be installed at 8 foot intervals above this point.

The nut and bolt supplied will fasten the band around the chimney.

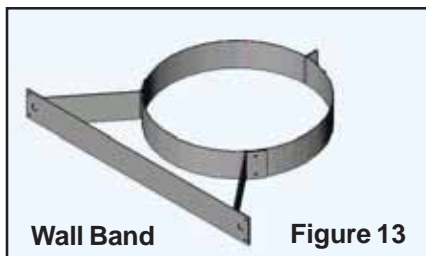

Fasten securely the Wall Band around the chimney with the supplied nut and bolt. Check for clearances and plumb as you fasten the Wall Bands to the wall. Use a level against the chimney section at each support stage to keep the assembly plumb.

Secure the Wall Band bracket to the wall using two 6d (2") spiral nails or #8 x 2" wood screws or longer if required through the pre-drilled holes (see Figure 13). For concrete or brick veneer walls use suitable masonry fasteners.

If the chimney penetrates an eave or overhang (soffit) cut an opening with 2" clearance all around. To find the exact spot where the chimney will pass through the eaves, drop a plumb line from the underside of the eaves to the outer edge of the leveled chimney. Mark 5 or 6 points to give an outline of the hole. Remember that the hole will need 2" clearance to the chimney surface. Install an Attic Insulation Shield if space permits on the under side of the overhang. If it is not possible, the overhang area can be enclosed and a Rafter Radiation Shield installed at the roof level and a Finishing Plate on the underside of the soffit. If the Attic is open to the overhang, close off the access with suitable building materials ensuring that a 2" air space clearance is maintained. From above, install the Roof Flashing and Storm Collar by following the Roof Flashing section in these instructions. If the overhang is not deep enough to allow the chimney to be fully installed within the overhang, it will be necessary to cut into it.

DO NOT INSTALL AN OFFSET TO CLEAR THE OVERHANG!

Ensure that a 2" air space clearance all around the chimney is respected. Framing and flashing the sides of the opening will be required. Install a Wall Band at this level.

NOTE: Interior chimneys installed with a Wall Support must use Firestop Joist Shield (FRS) in place of Wall Bands if extending through floor/ceiling penetrations and an Attic Insulation Shield when passing through an unoccupied attic space.

ADJUSTABLE INTERMEDIATE WALL SUPPORT

If the total chimney height exceeds the Wall Support limitations an Adjustable Intermediate Wall Support must be installed. Use of an AIWS will support an additional 38ft. of chimney. Slide the assembled Intermediate Wall Support over the protruding length of chimney. Fasten the Intermediate Wall Support to the wall using four 1/4" by 2" wood screws through the pre-punched slots in each bracket. Install the draw band around the protruding chimney length securely against the support plate. Install four stainless steel sheet metal screws firmly into the outer casing of the chimney, through the pre-punched holes in the draw band. Cover the heads of the screws with a non-hardening waterproof caulking.

CATHEDRAL CEILING SUPPORT

To complete a proper Cathedral Ceiling Support installation, the following parts will or may be required:

- Cathedral Ceiling Support (CCS): For sloped or angled ceiling.
- Stove Pipe Adaptor (ASE): Transition from chimney to flue pipe.
- Roof Flashing Assembly: Required when the chimney penetrates a roof.
- Suitable lengths of chimney: The chimney diameter should be sized to suit the appliance.
- Universal Shielding Insulation (JUSI): To stop cold air infiltration.
- Locking Bands (SLB): For added security at all joints.
- Rain Cap: Standard or Deluxe model.

The SuperVent/SuperPro Cathedral Ceiling Support will support a total of 38 feet of chimney of which 15 feet of chimney can be suspended below the support. The Cathedral Ceiling Support is screwed or nailed into framing installed between the roof rafters. Chimney joints made below the support must be secured with Locking Bands.

After framing in your opening to the dimensions specified in Table 1 found in the Framing Details section (measured in the horizontal plane), slide the Cathedral Support Box into the framed opening.

Once the box is at the desired position, ensure the box is level and nail the box to the framing using four 2" spiral nails or #8 x1-1/2" wood screws per side. The excess material sticking above the roof can either be trimmed off before attaching the box to the framing or, after it is installed the corners can be cut and the excess material folded down onto the roof deck.

Install the Support Band on the chimney length at the desired position by tightening the Support Band bolt and by screwing four stainless steel sheet metal screws through the Support Band (pre-punched holes) and into the outer casing.

NOTE: To reduce cold air infiltration into the dwelling you can install the optional Universal Shielding Insulation (JUSI) into the Cathedral Support Box. See separate installation instructions packaged with the JUSI.

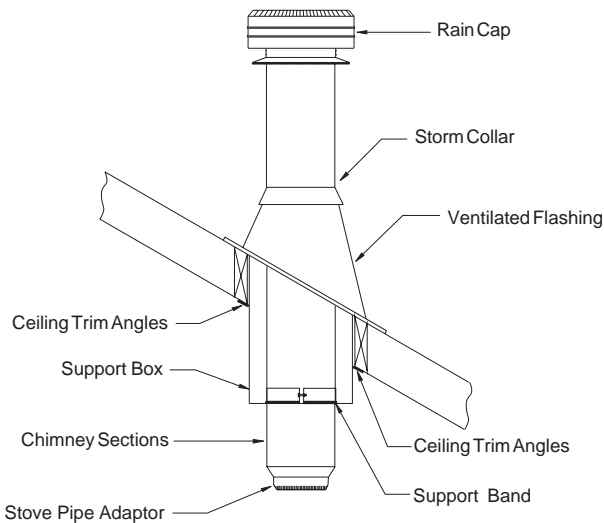

FIGURE 14 Cathedral Ceiling Support Installation

The bottom chimney length(s) must protrude through the opening of the Cathedral Support Box into the living space so that proper clearances are maintained from the stove pipe connector to the lower side of the ceiling. Refer to Chart 3 on page 16 at the back of these instructions for proper clearances. Do not offset the chimney below the Cathedral Support.

Lower the chimney length down through the opening in the bottom of the support so that the Support Band makes contact with the bottom of the Support Box. (See Figure 14).

NOTE: The male coupler of each chimney length must be up. Install additional chimney sections and lock together by turning clockwise until the two sections lock together snugly. Continue in this manner until the required height above the roof is achieved.

NOTE: Unlike normal inside installation, a cathedral ceiling installation provides only one support point for the chimney. This limited support can allow the chimney to sway slightly or vibrate in high winds conditions. It is advisable to install additional lateral support such as the use of a Roof Support or a Roof Guy Kit.

Chimney sections (15 feet max.) installed below the Cathedral Ceiling Support are locked together from below by turning clockwise until snugly locked together with each joint being secured by a Locking Band. These lengths can be painted to match the connector pipe with a high temperature heat resistant paint. To improve adhesion to the chimney, degrease, clean, prime before painting. Follow the paint manufacturer's instructions.

4 painted ceiling trim angles (2 short & 2 long) are supplied with fastening screws to finish off the Cathedral Support Box at the ceiling level. The 2 long pieces are trimmed off to match the pitch of the ceiling.

RAFTER RADIATION SHIELD:

A Rafter Radiation Shield (RRS) must be installed where the chimney is enclosed immediately below the roof line as shown in figure 18. An example of this is when the attic space of a house is being used as living space (ie. bedroom, guestroom etc.). It must also be installed when height restrictions will not allow the use of the Attic Insulation Shield (AIS) and the chimney has been enclosed with an enclosure around the chimney.

Attach the support brackets to the shield (through one of the three pre-punched holes) such that once the shield is installed, the shield protects both the upper and lower parts of the roof joist framing (See figures 15 & 19).

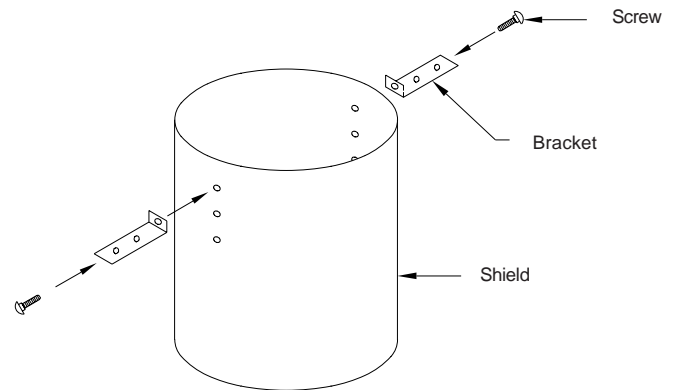

FIGURE 15 Rafter Radiation Shield Assembly

ROOF SUPPORT

The Roof Support may be used on a floor, ceiling or roof and adjusts to any roof pitch. It may be used above an offset to support the offset or as a supplementary support when the chimney height exceeds that of the primary support.

The Roof Support will support a total height of 50 feet of chimney sections of which 20 feet may be suspended beneath it. All chimney sections below the support must be secured with Locking Bands.

The Roof Support is mounted directly on the roof sheathing with its feet resting over rafters or a framed opening to form a solid base.

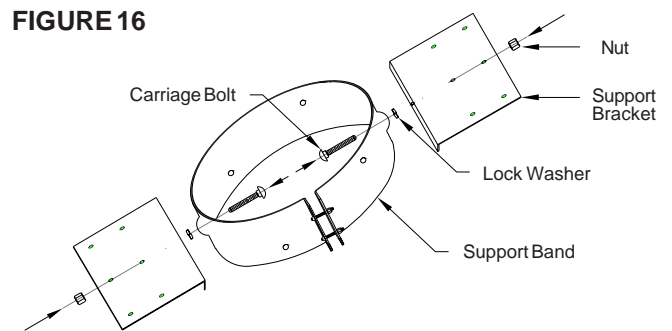

FIGURE 16 Roof Support Assembly

Frame a rectangular roof opening to provide a 2" minimum air space clearance from combustible material. The framing dimension is measured in the horizontal plane.

Attach the support brackets to the support band with the 1/2" nuts, bolts and lock washers. The lock washer is placed between the band and support bracket to provide proper spacing as shown in Figure 16.

Slide the Roof Support down over the chimney section until the support brackets rest on the roof or floor. Use a level against or on top of the Chimney Length to ensure that the chimney is plumb prior to the final position of the support brackets. Tighten the support band around the chimney with the nuts and bolts supplied, then secure the collar by screwing the 6 supplied sheet metal screws through the holes in the support band and into the chimney casing.

Center the chimney in the joist or rafter opening (ensure that the 2" required air space clearances are met) and nail or screw the support to the roof or floor using the 12 x 3-1/2" spiral nails supplied or 12 #8 x 1-1/4" wood screws.

Install additional Chimney Sections and lock together by turning clockwise until the two sections lock together snugly - continue in this manner until the desired height is achieved. The use of Locking Bands on all Chimney Lengths above the roof is highly recommended for added safety and stability when exposed to windy conditions.

NOTE: The male coupler of each chimney length must be up.

ROOF FLASHING:

Ensure that you have the proper Roof Flashing by checking your roof pitch using a level and two rulers (see fig. 17) or by using a roof pitch card.

The AAF Roof Flashing is for roof pitches from 0/12 to 6/12.
The AF2 Roof Flashing is for roof pitches from 6/12 to 12/12.

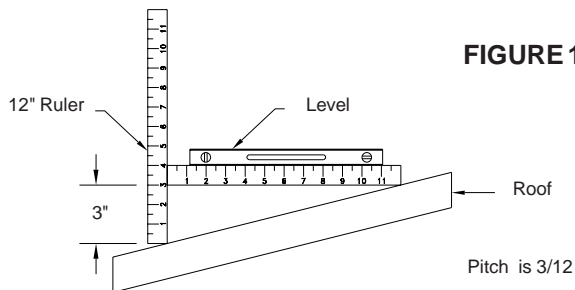

FIGURE 17

Roof Pitch Calculation

Find the centre of the opening by dropping a plumb bob from the inside of the roof sheathing to the centre of the leveled chimney length below. Do the same to find the outline of the required opening to the edge of the hole in the ceiling below (which includes the required clearance) mark several points forming the outline of the hole on the underside of the roof sheathing. Remember: these measurements are in the horizontal plane. Drill pilot holes following the marked outline.

Once you have marked and located the area where the chimney will come through the roof, position and prepare the roof area by removing shingles, shingle nails and cutting of the roofing material. Be careful when lifting roof shingles so they do not become damaged as they may be old or if the installation is done during cold weather. Frame the opening to suit the pitch of the roof and allowing for a 2" clearance to the chimney on all four (4) sides. This is done before extending the chimney above the roof.

Slide the top edge (nearest the roof peak) of the Flashing under the roof shingles. At least half of the Flashing should be UNDER the shingles

and the bottom edge OVER the shingles to provide a watershed. Trimming off the shingles may be necessary around the cone of the Flashing for a better fit. Do not nail the flashing to the roof yet as adjustments may be required.

Assemble Chimney Sections through the roof opening and Flashing. Ensure that all sections are locked together by turning clockwise until the sections lock snugly. Install Locking Bands to secure the chimney sections. Fasten the Flashing with 2 screws or nails. Before committing to a final position of the Flashing and Chimney, ensure the entire Chimney system is level and plumb and the required 2" air space clearance is maintained from all combustible material before permanently nailing and sealing of the Flashing to the roof.

Nail the Flashing to the roof deck (also under the shingles) along the upper edge and down each side with 12 nails with neoprene washers or cover the nails with a suitable non hardening waterproof caulking. Seal the shingles to the plate in the same manner. As a precaution, you may apply a bead of caulking along all seams of the Flashing.

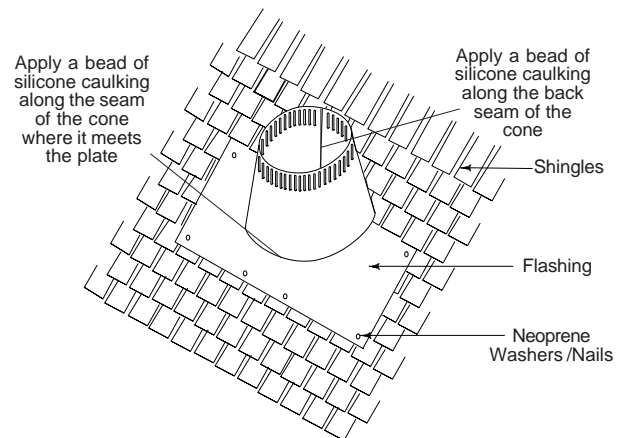

FIGURE 18

Roof Flashing Installation

Wrap the Storm Collar around the chimney above the Flashing. Secure the ends together loosely with the nut and bolt supplied or by sliding the appropriate tabs into slot.

Apply a non-hardening high temperature silicone caulking just above the top of the Flashing cone on the chimney casing. Slide the collar down the chimney until it contacts the Flashing and the caulking. Tighten the nut and bolt (or fold the tab over the slot) and apply additional caulking above the Storm Collar as required. After the installation check to ensure that the ventilation slots are not obstructed. (See Figure 19).

NOTE: A Rubber Boot Flashing Kit (URBFK1) is available as an option for passing through a corrugated or metal roof. See separate instructions packaged with the Rubber Boot Flashing Kit.

On metal or steep roofs, it is recommended that a chimney cricket fabricated from heavy-gauge galvanized steel be installed. This will protect the Chimney and the Flashing by routing the snow load and ice around the chimney. This is not a supplied item. Contact a sheet metal fabrication shop in your area for your custom chimney cricket.

The Flashing and Storm Collar may be painted to match the roof shingles. This will extend its life and improve the appearance. The chimney may be painted also with a HEAT RESISTANT paint. To improve adhesion to the SuperVent/SuperPro chimney, degrease, clean and prime before painting. Follow the paint manufacturer's instructions.

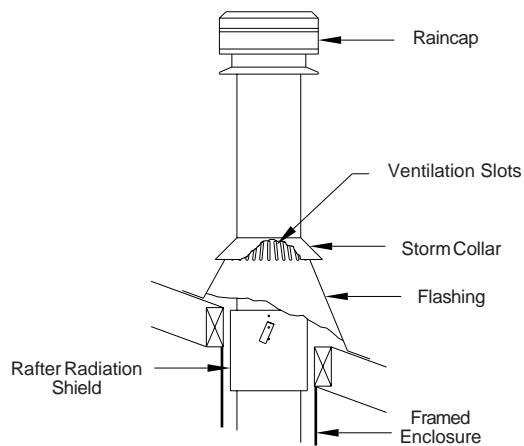

FIGURE 19 Storm Collar/Flashing Installation

WARNING: DO NOT BLOCK THE VENTILATION SLOTS ON THE FLASHING.

Continue adding Chimney Lengths until the proper height is achieved as per Figure 1 requirements (also see Chart 2 on page 15). Install Locking Bands at all chimney joints above the roof line for added security. Install the Rain Cap and lock it in place by turning clockwise until snug.

ROOF GUY INSTALLATION

If the chimney extends 5 feet or more above the roof line (measured from the upper slope), a Roof Guy Kit is required.

The Roof Guy Kit containing telescopic legs and draw band is suitable for this application. The draw band must be clamped around the chimney and the two legs lagged to the roof into the rafters and not just the roof sheathing. Position the band approximately two thirds of the way up the chimney height.

The preferred location for the band is next to a chimney joint, immediately above or below a Locking Band.

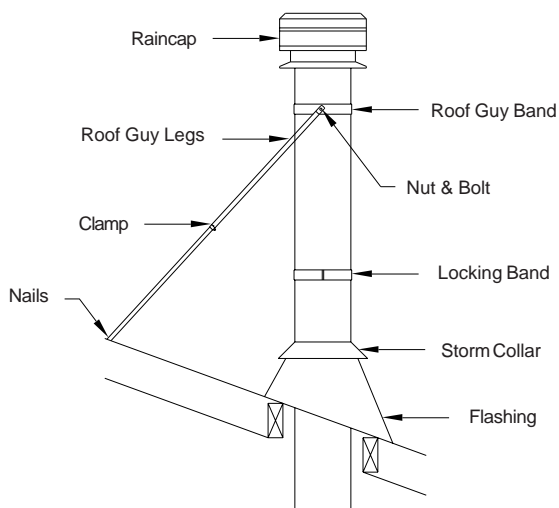

FIGURE 20 Roof Guy Installation

The two telescopic legs should form an angle of about 60 degrees to give support to the chimney in all directions. Keep bottom ends equal distance from the chimney and if possible, at the same elevation, on the high side of the sloped roof. Seal the roof with a suitable non-hardening waterproof caulking. After the legs are attached to the chimney and bands, tighten the clamps on the legs to fix the position of the telescoping legs. (See Figure 20).

Do periodic inspection of all fasteners including the clamps as high winds can cause the chimney system above the roof to vibrate and in time loosen some of the fasteners. Check all waterproof caulking and re-apply if need be.

UNIVERSAL ROOF GUY BAND (JURGK) ASSEMBLY INSTRUCTIONS

1. Measure the **outside** diameter of your chimney.
2. Mark the hole at each end of the band that corresponds to the diameter measured. These 2 holes along with the "Common" hole will be utilized for your particular chimney.

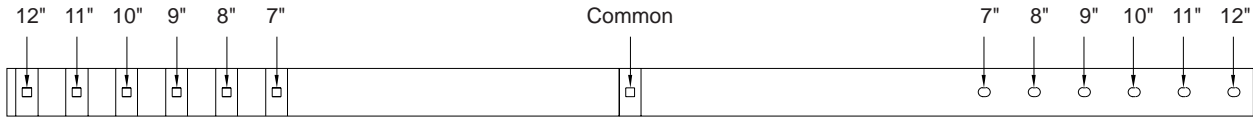

3. On the "Common" hole assemble 1 carriage bolt, 1 5/16" lock washer, 1 bracket, 1 1/4" lock washer and 1 1/4" hex nut in place as shown. Do not tighten the nut in place at this time

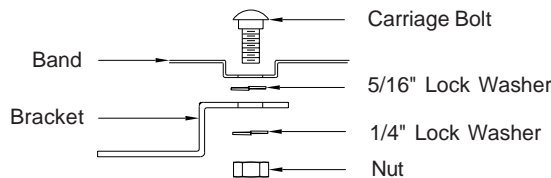

4. Install the band onto the chimney by placing the second carriage bolt through the correct size **square** hole, wrap the band around the chimney, and place the corresponding oval hole over the carriage bolt, and continue to assemble the remaining hardware as shown above. (On smaller diameter chimney the excess band material should be cut off)
5. Assemble roof guy legs by sliding supplied clamp over larger diameter leg and then inserting smaller diameter leg into larger diameter leg.
6. Temporarily hold legs together by tightening clamp over cut section of larger diameter leg.

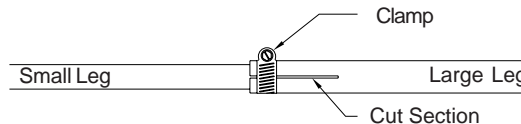

7. Attach the Roof Guy Legs (**non-bent end**) to the 2 brackets on the band using the 1" slot head screws, 1/4" lockwashers and 1/4" hex nuts.

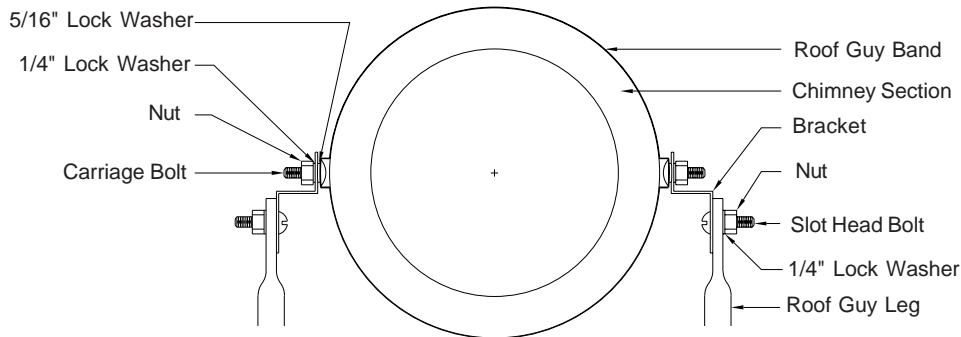

8. Loosen off roof guy legs, and extend them until they come in contact with the roof surface, and nail in place.
9. Re-tighten clamps on legs, tighten the band and brackets in place, and then tighten the legs to the band.

MAINTENANCE AND CLEANING OF CHIMNEY:

“Creosote and Soot - Formation and Need for Removal”

The need for chimney maintenance depends on the kind of appliance and how it is operated. Gas and oil-burning appliances need very little, but wood-burning appliances may need a great deal of chimney maintenance.

How you burn wood in your stove or fireplace directly affects the formation of creosote. Use more dry kindling and paper first to warm up the chimney system to a temperature between 350 to 500 degrees F. Burn hot, bright fires and fire each load hot. It is important to load your appliance properly and to avoid smoldering fires. Fast, effective start-ups are important, as is the moisture content of the wood being burned. If your wood is not completely seasoned, split your wood in smaller pieces instead of larger ones. Ideally, the moisture content of your firewood should be between 18 to 22%. A good investment in assisting you in monitoring your system is a surface thermometer for single wall stove pipe or a probe thermometer for double wall stove pipe. Ensure that only low sulphur content coal (1% or less) such as anthracite is burned.

When wood is burned slowly, it produces tar and other organic vapors, which combine with expelled moisture to form creosote. The creosote vapors condense in the relatively cool chimney flue of a slow-burning fire. As a result, creosote residue accumulates on the flue lining. When ignited, this creosote creates a chimney fire with extremely high temperatures.

With a new installation, the chimney should be inspected frequently (every 2 wks) to determine the rate of creosote formation. When familiar with the appliance and chimney characteristics, the chimney should be inspected at least once every 2 months during the heating season to determine if a creosote or soot build-up has occurred. Check spark arrestor screens at least every 2 to 4 weeks. If the spark arrestor becomes clogged with creosote, it must be cleaned or replaced. If creosote or soot has accumulated, it should be removed to reduce the risk of a chimney fire. Depending on the rate of build-up (as little as 1/16") and as you learn what is going on in the chimney, you can adjust your cleaning schedule accordingly. Every chimney flue and flue pipe shall be inspected annually and cleaned as often as may be necessary to keep the chimney and flue pipe free from dangerous accumulation of combustible deposits.

Chimney and flue pipe are particularly susceptible to off-season condensation. The incomplete combustion of wood produces acids which, when combined with moisture, are corrosive. During the heating season, corrosion tends not to occur because the heat in the system evaporates the condensation of any water vapour that may be formed.

Warm, moist air during the summer months passes slowly through the heating system. It makes any remaining ash or creosote moist and soggy. Corrosion of steel occurs where these deposits remain. Off-season corrosion can be reduced considerably if the system is thoroughly cleaned after the last fire of the heating season. Where coal is burned, the system must be thoroughly cleaned within 48 hours of shutting down the system for the season and all soot and ashes be removed from the chimney system. This should be the most careful cleaning the system receives all year. Air inlets should be closed and sealed if necessary to prevent the constant flow of air through the system.

Contact a professional certified chimney sweep for chimney cleaning services and advice if you have any doubts about your ability to clean your chimney system or if the task is too large. To visually inspect the chimney, remove the Rain Cap by simply using the twist-lock feature. Care should be taken not to disengage any lower chimney sections. This will permit the insertion of a flashlight for inspection and a properly sized plastic chimney cleaning brush. A metal brush may scratch the liner and lead to premature corrosion. The Tee Plug (if so equipped) can be removed by turning counter clockwise to clean from the bottom. Be sure to replace the Tee Plug and Rain Cap when you are finished inspecting and cleaning of the chimney.

If chemical cleaner is used to assist in the cleaning of your SuperVent/SuperPro chimney, make sure it is a product which is non corrosive. It does not replace the need for a mechanical cleaning. The optimal method for cleaning a chimney is by a mechanical brushing of the chimney in conjunction with a complete evaluation of the system by a certified chimney sweep.

CHIMNEY FIRES AND WHAT TO DO ABOUT THEM

Your SuperVent/SuperPro is **not** intended or designed for use as a combustion or fire chamber. It is very easy to overfire your woodburning appliance with kindling, scrap lumber, brush or any fast burning fuel. This can produce flames and high temperatures all the way up the chimney, and may cause chimney damage.

The following materials should not be burned in your woodburning appliance: pressure treated lumber, rail road ties, salt water driftwood or plastic. Burning such materials may lead to severe corrosion of the appliance and the chimney system.

If you see your appliance or the stove pipe glowing red, you are risking chimney damage, or a fire. The creosote may be burning inside the chimney. If you see flames coming out the top, you are either overfiring or there is a chimney fire. If the fire in your appliance has gotten out of control, or if you suspect a chimney fire for any reason, follow these steps:

1. Immediately close all dampers and/or air entrance openings to your appliance. This includes doors on Franklin type stoves. Block off fireplace openings.
2. Alert your family to the possible danger.
3. Inspect your appliance and chimney surroundings for possible fire. If in doubt, alert your Fire Department.
4. Do not continue to use your appliance until it and your chimney have been thoroughly inspected. Overheating can cause metal parts to expand, buckle and crack. If you are not certain, have a certified wood technician or certified chimney sweep disassemble all parts so they can be inspected and replaced.
5. Do not use salt or water on the fire in your appliance. Salt is corrosive and water will cause a dangerous steam explosion. You might be able to control the fire by using ashes, sand or baking soda. Baking soda is an ingredient used for dry chemical fire extinguishers.
6. After a chimney fire, when it is safe to do so, check internal locations such as the attic and under the roof and keep watching for two or three hours. There may be delayed smoldering and subsequent ignition, even if the fire inside the chimney has been controlled.

WARNING:
DO NOT USE FUEL MATERIALS CORROSIVE TO THE CHIMNEY LINER SUCH AS DRIFTWOOD, PLASTICS, CHEMICALLY TREATED WOOD, ETC.

CHART 1 - OFFSET CHIMNEY INSTALLATION

It may be necessary to offset the chimney in order to clear a joist or an obstacle. The three (3) charts below will assist you in selecting the proper combination of elbow angle and chimney length(s) that will provide the necessary degree of offset within an available height.

1. Select the column with the proper chimney diameter of your system.

2. Determine the distance of the offset required by dropping a plumb line for an accurate measurement. The offset is measured at the chimney centre line as per the "A" Offset measurement in the diagram below.

3. On the chart, find the predetermined distance (under the "A" column) required for the 15° elbow. For greater offset, use the 30° or 45° offset charts. NOTE: The 45° elbows may be used **ONLY** with oil or gas appliances.

4. After finding the offset, look at the "B" (height) measurement in the chart to find the specified height. The appropriate "chimney lengths" required in between elbows is found in the left hand side column of each charts.

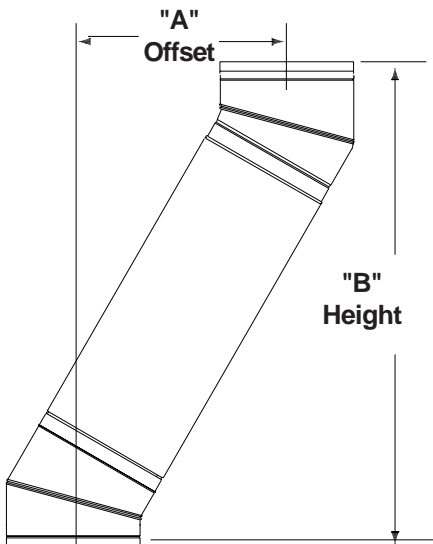

NOTE:

• SuperVent/SuperPro chimneys are limited to offsets not exceeding 30 degrees. Combining offsets for greater angle is not permitted. **The 45° elbows may be used ONLY with oil or gas appliances.**

• One pair of (two) elbows may be used for interior installation only.

• Never install an elbow in a joist area. Chimney sections must pass vertically through framed joist areas.

• Locking Bands must be use at all chimney joints.

• Each elbow support will support 15 feet of chimney.

• The maximum length of chimney allowed between elbows is 6 feet.

Chimney Lengths	5" Diameter		6" Diameter		7" Diameter		8" Diameter	
	A	B	A	B	A	B	A	B
none	1-1/2"	9"	1-1/8"	10"	1-1/8"	10-1/4"	1-1/4"	10-3/8"
6"	2-1/8"	13-1/2"	2-3/8"	14-1/4"	2-3/8"	15"	2-1/2"	15-5/8"
12"	4"	19-1/8"	4"	20-1/2"	4-1/16"	20-3/4"	4-1/8"	21"
18"	5-1/2"	25"	5-1/2"	26-1/4"	5-1/2"	26-1/2"	5-5/8"	26-3/4"
24"	7-1/2"	30-1/2"	7"	32"	7-1/16"	32-1/4"	7-1/8"	32-1/2"
36"	10-1/8"	42"	10-1/4"	43-5/8"	10-1/4"	44"	10-1/4"	44-1/8"
6" + 36"	11-1/4"	48-1/4"	11-3/8"	48-3/8"	11-1/2"	48-5/8"	11-1/2"	48-7/8"
12" + 36"	12-3/4"	54"	13"	54-1/8"	13"	54-3/8"	13"	54-5/8"
18" + 36"	14-3/8"	59-3/4"	14-1/2"	60"	14-1/2"	60-1/8"	14-5/8"	60-3/8"
24" + 36"	16"	65-1/2"	16-1/8"	65-3/4"	16-1/8"	66"	16-1/8"	66-1/4"
12"+24"+36"	19"	76-1/4"	19"	76-1/4"	19"	76-1/2"	19"	76-3/4"

Chimney Lengths	5" Diameter		6" Diameter		7" Diameter		8" Diameter	
	A	B	A	B	A	B	A	B
none	3"	10"	2-3/4"	11-5/8"	3-1/8"	13"	3-1/2"	14-1/2"
6"	5-1/4"	14"	5-1/4"	15-7/8"	5-5/8"	17-1/4"	6"	18-3/8"
12"	9"	19-1/4"	8-1/4"	21"	8-5/8"	22-3/8"	9"	24"
18"	11-1/4"	24-1/2"	11-1/4"	26-1/4"	11-5/8"	27-5/8"	12"	29-1/8"
24"	14-1/4"	29-3/4"	14-1/4"	31-3/8"	14-5/8"	32-7/8"	15"	32-3/8"
36"	20"	39-3/4"	20-1/4"	41-7/8"	20-5/8"	43-1/4"	21"	44-3/4"
6" + 36"	21-7/8"	44-1/2"	22-5/8"	46"	23"	47-1/2"	23-1/2"	49"
12" + 36"	23-7/8"	50-1/8"	25-5/8"	51-1/4"	26"	52-5/8"	26-1/2"	54-1/8"
18" + 36"	27-1/8"	55-1/8"	28-5/8"	56-3/8"	29"	57-3/8"	29-1/2"	59-3/8"
24" + 36"	30-3/8"	60-5/8"	31-5/8"	61-5/8"	32"	63"	32"	64-1/2"
12"+24"+36"	37"	69-3/8"	37-1/8"	71"	37-1/2"	72-1/2"	38"	74"

Chimney Lengths	5" Diameter		6" Diameter		7" Diameter		8" Diameter	
	A	B	A	B	A	B	A	B
none	6"	10-1/8"	4-3/8"	12"	5-1/2"	14"	5-3/4"	15-1/8"
6"	9-1/8"	13-5/16"	7-3/4"	15-5/8"	9-3/4"	18"	9-1/2"	19-1/4"
12"	13-3/8"	17-1/2"	11-7/8"	19-3/4"	13"	21-3/4"	13"	22-1/2"
18"	17-5/8"	21-3/4"	16"	23-7/8"	17-1/4"	25-3/8"	17"	27"
24"	21-13/16"	26"	20-1/2"	27-3/4"	21-3/4"	29-7/8"	21-5/8"	31"
12" + 24"	29-5/16"	33-7/16"	23-7/8"	31-3/8"	25-5/8"	32-3/4"	24-5/8"	34-1/2"
36"	30-3/8"	34-1/2"	28-1/2"	36-7/8"	30-5/8"	38-1/8"	29-5/8"	39-7/8"
12" + 36"	37-3/4"	41-7/8"	36-1/4"	44-3/8"	38-1/8"	45-1/8"	38-1/8"	47"
18" + 36"	42"	46-3/16"	40-1/8"	49-1/4"	42-3/4"	49-1/4"	41-7/8"	51-1/2"
24" + 36"	46-1/4"	50-7/16"	47-7/8"	56-1/2"	50-1/2"	57-3/8"	49"	59-3/8"
12"+24"+36"	53-5/8"	57-7/8"	41-1/2"	45-5/8"	38-1/4"	46-1/2"	38-1/2"	48-7/8"

All measurements are in inches. Construction tolerances ± one inch.

CHART 2 - CHIMNEY HEIGHT ABOVE THE ROOF

Requirement # 1 : The code requires that the chimney must extend at least 3 feet above the highest point of the roof that it penetrates.

Requirement # 2 : It must also be 2 feet above any roof, wall or other obstruction within a horizontal distance of 10 feet.

The following Chart is to assist you in determining the minimum chimney height you will require above the roof. You may need to add to this height as nearby buildings, trees and other parts of the house roof could interfere with airflow over and around the top of the chimney and affect its performance. If you think a nearby obstacle could affect draft, you might want to install one or more additional lengths.

DISTANCE FROM PEAK	PITCH OF ROOF											
	1/12	2/12	3/12	4/12	5/12	6/12	7/12	8/12	9/12	10/12	11/12	12/12
	CHIMNEY HEIGHT ABOVE ROOF (INCHES)											
10 Ft	*36	44	54	64	74	84	94	104	114	124	134	144
9 Ft	*36	42	51	60	69	78	87	96	105	114	123	132
8 Ft	*36	40	48	56	64	72	80	88	96	104	112	120
7 Ft	*36	38	45	52	59	66	73	80	87	94	101	108
6 Ft	*36	36	42	48	54	60	66	72	78	84	90	96
5 Ft	*36	*36	39	44	49	54	59	64	69	74	79	84
4 Ft	*36	*36	36	40	44	48	52	56	60	64	68	72
3 Ft	*36	*36	*36	36	39	42	45	48	51	54	57	60
2 Ft	*36	*36	*36	*36	*36	36	38	40	42	44	46	48
1 Ft	*36	*36	*36	*36	*36	*36	*36	*36	*36	*36	*36	36

* Defaulted to 36" to meet requirement #1. Both requirements (#1 and #2) must be met.

- If the chimney extends 5 feet or more above the roof, a Universal Roof Guy Kit (JURGK-1) is required.
- It is highly recommended that any lengths above the roof should have locking bands at all joints for added safety and stability. This will eliminate the risk of sections becoming undone below the roof line when the Rain Cap is removed during inspections and cleaning of the system is being done.

CHART 3 - Connector Pipe Clearance below Cathedral Support

1. Identify the type of connector pipe you will be installing, single wall (requires 18" clearance to combustibles) or Selkirk's Double Wall Stove Pipe (model DSP) which requires 6" clearance to combustibles.
2. Determine the amount of the exposed Cathedral Support that will be projecting into the room as per the "X" in the diagram on the bottom left.
3. Select the pitch of your sloped ceiling from the chart below.
4. Select the measurement from the chart below where the pitch of the sloped ceiling column intersects with the exposed Cathedral Support row selection. This will determine the measurement of insulated chimney required below the Cathedral Support as per the "Y" in the diagram on the left. The minimum of insulated chimney below the Cathedral Support is 1 inch. This minimum is required for stability of the system.

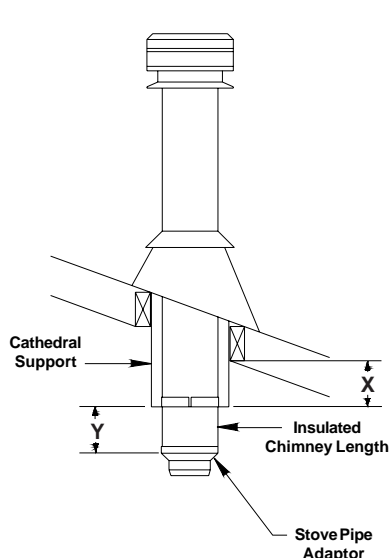

CONNECTOR PIPE CLEARANCE REQUIREMENTS FROM SLOPED CEILING													
EXPOSED CATHEDRAL SUPPORT INTO ROOM		PITCH OF SLOPED CEILING											
		1/12	2/12	3/12	4/12	5/12	6/12	7/12	8/12	9/12	10/12	11/12	12/12
1 Single Wall Flue Pipe	"X" measurement	"Y" MEASUREMENT - INSULATED CHIMNEY LENGTH INTO ROOM											
	Box flush to ceiling on lower end	1.5	3	4.5	6	8	9	10.5	12	13.5	15	16.5	18
	Box 1" into the room	1	2	3.5	5	7	8	9.5	11	12.5	14	15.5	17
	Box 2" into the room	1	1	2.5	4	6	7	8.5	10	11.5	13	14.5	16
	Box 3" into the room	1	1	1.5	3	5	6	7.5	9	10.5	12	13.5	15
2 DSP - Double Wall Stove Pipe	"X" measurement	"Y" MEASUREMENT - INSULATED CHIMNEY LENGTH INTO ROOM											
	Box flush to ceiling on lower end	1	1	1.5	2	2.5	3	3.5	4	4.5	5	5.5	6
	Box 1" into the room	1	1	1	1	1.5	2	2.5	3	3.5	4	4.5	5
	Box 2" into the room	1	1	1	1	1	1	1.5	2	2.5	3	3.5	4
	Box 3" into the room	1	1	1	1	1	1	1	1	1.5	2	2.5	3

¹ Single Wall Flue Pipe requires 18" clearance to any combustible materials.

² DSP Double Wall Stove Pipe requires 6" clearance to any combustible materials.

All measurements are in inches.

REPLACEMENT PARTS LIST

DESCRIPTION	SUPERPRO PART N°.	SUPERVENT PART N°.
48" Chimney Length	PR*L48	N/A
36" Chimney Length	SPR*L36	JSC*SA3
24" Chimney Length	SPR*L24	JSC*SA2
18" Chimney Length	SPR*L18	JSC*SA18
12" Chimney Length	PR*L12	JSC*SA1
6" Chimney Length	SPR*L6	JSC*SA6
Tee with Plug	SPR*ITP	JSC*SITS
Insulated Tee Plug	J*1TPI	J*1TPI
15° Elbow Kit	SPR*EL15K	JSC*SEK
30° Elbow Kit	SPR*EL30K	JSC*SE3K
45° Elbow Kit	SPR*EL45K	JSC*SE4K
Ceiling Support	SPR*CSB	JSC*DCS
Adjustable Wall Support	JSC*AWS	JSC*AWS
Adj. Interm. Wall Support	JSC*AIWS	JSC*AIWS
Cathedral Ceiling Support	SPR*CCSB	JSC*CCSB
Roof Support	JSC*RS	JSC*RS
Elbow Support	JSC*ES	JSC*ES
Locking Band	SPR*SLB	JSC*SLB
Stove Pipe Adaptor	JSC*ASE	JSC*ASE
Wall Thimble	SPR*WTB	JSC*WT
Trim Collar	J*TC	J*TC
Wall Band	JSC*WB	JSC*WB
Adjustable Ceiling Plate	JSC*CT	JSC*CT
Universal Roof Guy Kit	JURGK-1	JURGK-1
Adaptor Plate	JSC*AP	JSC*AP
Firestop Joist Shield	JSC*FRS	JSC*FFS
Attic Insulation Shield	JSC*AIS	JSC*AIS
Rafter Radiation Shield	JSC*RRS	JSC*RRS
Finishing Plate	J*FP	J*FP
Deluxe Rain Cap	SPR*DRC	JSC*DRC
Standard Rain Cap	N/A	JSC*RC
Spark Arrestor	SJSC*SPAR	JSC*SPAR
Flat Roof Flashing	JSC*ATC	JSC*ATC
0/12-6/12 Roof Flashing	JSC*AAF	JSC*AAF
6/12-12/12 Roof Flashing	JSC*AF2	JSC*AF2
Storm Collar	JSC*SC	JSC*SC
Universal Shielding Insulation	JUSI	JUSI
Rubber Boot Flashing Kit	URBFK1	URBFK1

* Specify chimney size

Model SuperVent (JSC) and SuperPro (SPR) chimney and components are interchangeable with one another. Both are listed to UL103 Type HT.

INSTALLATION INFORMATION

Keep in a safe place for future reference

CHIMNEY MODEL: _____

TYPE OF APPLIANCE: _____

INSTALLATION DATE: _____

DESCRIPTION OF INSTALLATION (Chimney and Flue Pipe Configuration) _____

PURCHASED FROM:

DEALER NAME: _____

Address: _____

City: _____

State: _____

INSTALLED BY:

TECHNICIAN NAME: _____

Address: _____

City: _____

State: _____



PRODUCT REGISTRATION

Please register your Chimney with the Manufacturer.

Mail to: Selkirk Corporation,
Product Registration, 3050 Corporate Exchange Blvd., Grand Rapids, MI 49512

Register Online @: www.selkirkcorp.com

Name: _____

Address: _____

City: _____

State: _____ Zip Code: _____ Telephone #: _____

Chimney Model: _____ Installation Date: _____

Technician Name: _____ Address: _____

City: _____ State: _____ Zip Code: _____ Telephone #: _____

“SMART CHOICE” LIMITED LIFETIME WARRANTY

Selkirk Corporation, (“Selkirk”, “we”, “us”, “our”) warrants our residential Chimney & Venting products (* defined below) to be free from defects in material and workmanship. For products installed after January 1, 2009, for a period of Ten (10) years from original installation, we will provide replacement product with a similar or like quality of available Selkirk product, **free of charge**, excluding any installation costs. From the Eleventh (11) through Fifteenth (15) years, we will provide replacement product at a cost of 75% off the published Retail Price in effect on the date the claim is received, excluding any installation costs. At expiration of the Fifteen (15) year term, we will provide replacement product at a cost of 50% off the published Retail Price in effect on the date the claim is received excluding any installation costs. This warranty coverage is non-transferable and applies exclusively to the original consumer.

PROFESSIONAL INSTALLATION:

If installation is performed by Professional Installers certified in Canada by WETT or APC or in the USA by NFI or CSIA, we will provide replacement product with a similar or like quality of available product, free of charge (excluding any installation costs) for the full Fifteen (15) years from the date of original installation. To be eligible for this additional warranty the consumer must provide a proof of installation by a Professional Installer when submitting a claim.

LIMITATIONS:

BUYER’S REMEDIES ARE LIMITED TO REPAIR OR REPLACEMENT OF THE PRODUCT AND DO NOT INCLUDE INSTALLATION COSTS. EXCEPT AS SET FORTH HEREIN, ALL OTHER WARRANTIES (EXPRESS OR IMPLIED, INCLUDING THE WARRANTIES OF MERCHANTABILITY AND FITNESS FOR A PARTICULAR PURPOSE) ARE HEREBY DISCLAIMED. IT IS AGREED THAT THIS SHALL BE THE SOLE AND EXCLUSIVE REMEDY OF THE BUYER. IN NO EVENT SHALL WE BE LIABLE FOR ANY CONSEQUENTIAL, SPECIAL OR PUNITIVE DAMAGES ARISING DIRECTLY OR INDIRECTLY FROM THE USE OF THE PRODUCTS WHETHER BASED ON WARRANTY, CONTRACT NEGLIGENCE OR STRICT LIABILITY.

ALL LENGTHS, TEES, ELBOWS, AND COMPONENTS SUPPLIED BY US ARE SUBJECT TO WARRANTY COVERAGE. PRODUCT SUPPLIED BY US AS REPLACEMENT FOR ORIGINAL MATERIAL WILL BE SUBJECT TO A ONE-YEAR WARRANTY COVERAGE.

WARNING: FAILURE TO INSTALL OR OPERATE PRODUCTS ACCORDING TO THE MANUFACTURER’S INSTRUCTIONS, OR FAILURE TO USE PRODUCTS WITH RESIDENTIAL APPLIANCES THAT HAVE BEEN CERTIFIED AT AN ACCREDITED LABORATORY WILL VOID ALL APPLICABLE WARRANTIES.

THIS WARRANTY DOES NOT COVER:

- (a) any non-stainless base tee unit mounted or connected to an Insulated Chimney system;
- (b) costs (labor or otherwise **) associated with either removing a previously installed product, installing a replacement product, transportation or return of a product, or transportation of replacement product;
- (c) damage to the finish of products caused by the use of improper solvents/chemicals or improper (or lack of) cleaning methods;
- (d) damage resulting from normal wear and tear or failure to reasonably clean, care for or maintain products in accordance with our installation instructions/recommendations;
- (e) damage (to products, appliances or structure) based on or resulting from improper installation or repair, misuse or abuse (including, but not limited to, excessive or improper operating condition), or alteration or adjustment other than in conformity with our installation instructions and specifications, whether performed by a contractor, service company, technician, or yourself;
- (f) any products that have been moved from their original installation site;
- (g) damage caused by burning driftwood, garbage, or any other prohibitive material that has been burned in the appliance served by the chimney;
- (h) damage that results from accidents such as fire, flood, high winds, “acts of God”, or any other contingency beyond our control.

** Due to the wide variance in installation practices and other conditions beyond our control, except as stated above, we do not guaranty or in any way warrant the installation of Chimney and Venting products.

CLAIM PROCEDURE: If you believe that a product is defective, notify us in writing at:

SELKIRK CANADA CORPORATION

P. O. Box 526, Depot 1,
Hamilton, Ontario, CANADA, L8L 7X6
ATTN: WARRANTY CLAIMS
1.888.735.5475
www.selkirkcorp.com

SELKIRK CORPORATION

5030 Corporate Exchange Blvd.,
Grand Rapids, MI 49512
ATTN: WARRANTY CLAIMS
1.800.433.6341
www.selkirkcorp.com

Notification should include a description of the product, model and serial number (if applicable) and a description of the product defect. Upon receipt of a written claim under this limited warranty and evidence of the date of purchase or installation, at our option and in our sole discretion, we will provide replacement product with similar or like quality of available product excluding any installation costs. We reserve the right to inspect or investigate any warranty claims prior to determining whether to provide replacement product. If, as determined by us, that repair or replacement of the product is not commercially practicable or cannot be completed in a timely manner, we may refund the prorated purchase price paid for the product upon verification by providing a copy of your invoice or receipt of bill of sale.

*Selkirk products covered under this warranty: AFCL, ALT, BV (SD, MD, LD), DFS, DSP, DT, DT-M, DWC/SWC, FC (JSC), GT, GTL, PL, QC, RF, RV, SC (JM), SFCL, SPR, ST, U1, UT, UTL, VP, WV.