

AAMA 2410-03

**Standard Practice For
Installation Of Windows
With An Exterior Flush
Fin Over An Existing
Window Frame**





TABLE OF CONTENTS

1.0 Scope.....	1
2.0 Referenced Documents.....	1
3.0 Definitions.....	1
4.0 Significance And Use.....	2
5.0 Pre-Installation Inspection.....	2
6.0 Procedure	2
7.0 Product Protection	3



AAMA. The Source of Performance Standards, Product Certification and Educational Programs for the Fenestration Industry.

This voluntary specification was developed by representative members of AAMA as advisory information and published as a public service. AAMA disclaims all liability for the use, application or adaptation of materials published herein.

©2003

American Architectural Manufacturers Association

1827 Walden Office Square, Suite 550, Schaumburg, IL 60173

PHONE 847/303-5664 FAX 847/303-5774

EMAIL webmaster@aamanet.org WEBSITE www.aamanet.org

All AAMA documents may be ordered at our web site in the "Publications Store".

Publish Date: 2003

1.0 SCOPE

1.1 This practice covers the installation of retrofit windows in residential buildings of no more than four (4) stories in height.

1.2 This practice applies to retrofit windows with an exterior flush fin installed over a pre-existing window frame into a vertical wall.

1.3 This practice covers the installation process from pre-installation procedures through post-installation procedures. It does not cover the fabrication or assembly of windows whether such fabrication takes place in a factory or at the intended installation site.

1.4 This practice covers aspects of installation relating to installation effectiveness and reasonable durability in service. It does not cover aspects of installation relating to window handling and storage or the safety of the person installing the windows.

1.5 This practice provides minimum requirements that will help to ensure the installation of exterior flush fin retrofit windows in an effective manner. Actual conditions in buildings vary greatly, and in some cases substantial additional care and precaution will have to be taken.

1.6 This practice assumes that the seal between the pre-existing window and adjacent wall weather resistant barrier is adequate and that the wall surrounding the pre-existing window is structurally sound.

1.7 This practice covers typical installations and generic details. It does not purport to cover all situations that may be encountered in the field.

1.8 This practice does not purport to address all of the safety concerns associated with its use. It is the responsibility of whomever uses this standard to consult and establish appropriate safety and health practices and determine the applicability of regulatory limitations prior to use.

1.9 This practice is not intended to replace a manufacturer's installation instructions or federal, state, or local building codes. In all cases follow manufacturer's instructions and applicable building codes for any special procedures, applications, or requirements.

2.0 REFERENCED DOCUMENTS

2.1 AAMA

AAMA 800-92, "Voluntary Specifications and Test Methods for Sealants"

AAMA TIR A9-00, "Metal Curtain Wall fasteners"

AAMA IM-TM-00, "Installation Masters Training Manual"

2.2 ASTM

ASTM E 2112-01, "Standard Practice for Installation of Exterior Windows, Doors and Skylights"

ASTM B 633-98 E1, "Standard Specification for Electrodeposited Coatings of Zinc on Iron and Steel"

ASTM B 766-86, "Standard Specification for Electrodeposited Coating of Cadmium"

ASTM B 456-95, "Standard Specification for Electroplated Coatings of Copper Plus Nickel Plus Chromium and Nickel Plus Chromium"

3.0 DEFINITIONS

3.1 Residential Building- Any building used or intended primarily for single or multiple dwelling units.

3.2 Retrofit Window- A replacement window designed to be installed over a pre-existing window frame.

3.3 Flush Fin- A fin projecting from the exterior surface of the window frame parallel to the building wall for the purpose of acting as an outside trim molding.

3.4 Weather Resistant Barrier- The surface or surfaces of a wall responsible for preventing water infiltration into the building, such as: flashing, building paper, house wrap and sealant.

3.5 Mounting Surface- The exterior surface(s) of the pre-existing window frame.

3.6 Daylight Opening- Minimum clear opening of the pre-existing window frame after removal of sash, glass and all sash components.

3.7 Shim- A thin, flat or wedge shaped piece of suitable material used to level or plumb a window frame during installation.

3.8 Sealant- Any of a variety of compounds used to fill and seal joints or openings in wood, metal, masonry, and other materials, as contrasted to a sealer; which is a liquid used to seal a porous surface. Some common types of sealants are: polysulfide, silicone, acrylic latex, butyl, and polyurethane.

3.9 Blocking- A lineal piece of suitable material designed to support and prevent rotation of the replacement window sill.

4.0 SIGNIFICANCE AND USE

4.1 This practice recognizes that the effectiveness and durability of installed windows depend not only on the choice and quality of material, design, adequacy of assembly, and support system, but also on their proper installation.

4.2 Improper installation of windows may hinder operation or reduce their effectiveness, by allowing excessive air, water and sound infiltration or condensation. It may promote the deterioration of the wall construction and its respective components.

4.3 The application of this practice also requires a working knowledge of applicable Federal, State and local codes and regulations regarding windows, specifically, but not limited to: a) a required emergency escape and rescue opening; b) requirements for safety glazing; and c) an understanding of construction practices relating to the building wall weather resistant barrier system. Consult with local building codes prior to installation.

4.4 The application of this practice also requires a working knowledge of the tools, equipment, and methods necessary for the installation of windows. It further assumes familiarity with caulking, sealing, painting (where applicable) and glass handling procedures. It also requires an understanding of the fundamentals of residential construction that affect the installation of these windows.

5.0 PRE-INSTALLATION INSPECTION

5.1 Inspect the interior and exterior walls adjacent to the window to be retrofitted. If evidence of water penetration is observed or suspected, corrective measures shall be taken prior to installation.

5.2 Carefully inspect the existing window frame perimeter for evidence of damage, deterioration or decay. These conditions shall be addressed prior to the installation of the retrofit window.

6.0 PROCEDURE

6.1 Measuring For Retrofit Windows

6.1.1 Measurements must be taken to determine daylight opening sizes and to ensure squareness.

6.1.2 To determine the daylight opening size, three measurements shall be taken horizontally between the pre-existing jambs at the corners and at the center, recording the smallest dimension. Three measurements

shall also be taken vertically from the pre-existing head to the pre-existing sill at the corners and at the center, recording the smallest dimension (see Figure 1).

6.1.3 Determine squareness of the opening by cross-measuring the opening (see Figure 2).

6.2 Sizing of Retrofit Windows

6.2.1 Accuracy of size is critical. Sizing shall allow for proper fit without having to rack or force the retrofit window into the daylight opening.

6.2.2 The retrofit window shall be approximately 6 mm (1/4 in) less in width and height than the measurements of Section 6.1.2. Out of square conditions may require additional allowances.

6.3 Protection from Dissimilar Metals

6.3.1 Metal products shall be isolated from dissimilar or corrosive materials with a nonconductive coating, membrane or sealant material.

6.3.2 All fasteners shall be corrosive resistant, in accordance with ASTM B 633, B 766, or B 456 as indicated in AAMA TIR A9.

6.4 Preparation and Installation

6.4.1 Verify that the retrofit window will fit in the daylight opening and that the flush fin will cover the exterior of the pre-existing window's frame.

6.4.2 Prepare the opening by removing any pre-existing sash components that will interfere with the installation of the retrofit window. Trim protruding elements of the pre-existing window frame as required. Leave only the pre-existing window's outer frame in place (see Figure 3).

NOTE: In removing existing materials, it is important not to disturb the pre-existing weather resistant barrier, as it will still be utilized. If the pre-existing weather resistant barrier is damaged, corrective measures shall be taken prior to the installation of the retrofit window.

6.4.3 Ensure that the pre-existing frame's exterior mounting surface is clean and free of any debris and will allow for full perimeter contact with the flush fin of the retrofit window. Trimming the exterior flush fin of the retrofit window may be required.

6.4.4 Install window, making sure to level it and block it as necessary, or as directed by the manufacturer to ensure that the frame will be well supported along its base to prevent sill rotation or distortion (see Figures 4 & 8). Do not block any weep holes on the pre-existing window.

6.4.5 Pre-fit the retrofit window in the opening. Square and shim as necessary for a level, plumb and square installation. Secure sufficiently to check for proper operation, locking and fit. Remove retrofit window from the opening. Trim the perimeter of the retrofit flush fin if necessary. (See AAMA IM-TM-00 for additional information on shimming.)

6.4.6 Apply a minimum 10 mm (3/8 in) continuous bead or ribbon of sealant to the mounting surfaces of the pre-existing window frame across the head and down the jambs. An adequate amount of sealant shall be applied to compensate for irregularities in the wall surface to ensure a proper seal between the pre-existing window frame and the flush fin of the retrofit window (see Figure 5).

6.4.7 Apply a minimum 10 mm (3/8 in) bead or ribbon of sealant across the exterior mounting surface of the sill, leaving a minimum void of 25 mm (1 in) in-line with existing weep holes to allow any moisture to escape.

Do not block any weep openings on the pre-existing window (see Figure 6).

NOTE: Where no weep openings exist, leave two (2) – 25 mm (1 in) minimum voids. One each within 100 mm (4 in) from each corner.

6.4.8 Place the retrofit window into the opening. Push firmly to ensure contact with the sealant on the pre-existing frame to achieve a primary seal between the pre-existing frame and retrofit window (see Figure 7).

NOTE: Confirm installation is level, plumb and square. Install and check vent panels for proper operation, locking and fit. Make adjustments as necessary in accordance with window manufacturer's instructions.

6.4.9 Secure the retrofit window in the opening. Screw through both the retrofit and pre-existing window frame head and jambs and anchor into the surrounding wall framing. Installation screws shall be no closer than 75 mm (3 in) and no more than 250 mm (10 in) from each corner and at a maximum of 400 mm (16 in) on center. Do not over-tighten screws as this may warp or bend the retrofit window's frame. Shims are recommended at each fastener. Seal screw hole openings both prior to and after installation of the screw.

6.4.10 If the window is sufficiently large to require anchoring of the sill, consult manufacturer's instructions. Anchor the sill in a fashion that will not violate the pre-existing window's sill drainage system.

CAUTION: *Do not* screw through the pre-existing window's sill in a fashion that may allow water to penetrate the weather resistant barrier.

6.4.11 Apply a secondary seal, between the fin and the adjacent building wall materials, around the perimeter of the retrofit window's flush fin (see Figure 8). Leave minimum voids of 25 mm (1 in) in line with the pre-existing window's weep holes to allow for drainage (see Figure 7).

NOTE: Where no weep openings exist, leave two (2) – 25 mm (1 in) minimum voids. One each within 100 mm (4 in) from each corner.

6.4.12 If gunnable foam products are used to insulate on the interior, only use low pressure foam products to avoid distortion of the window frame.

6.4.13 Finish the interior of the retrofit window with desired trim. It is recommended to not install any interior trim within 30 minutes of a foam insulation application.

6.5 Sealant Requirements

6.5.1 Installation sealant shall conform to AAMA 800. Use compatible sealant recommended and approved by the sealant manufacturer, following their printed application procedures. ASTM E 2112 provides guidance on sealant selection and application.

6.5.2 Where sealant is required in this standard, an application of a nominal 10 mm (3/8 in) diameter sealant bead or ribbon as recommended by the sealant manufacturer is required.

6.5.3 Install the window immediately after sealant application before a skin forms and/or contamination occurs on the sealant surface.

7.0 PRODUCT PROTECTION

7.1 Caution shall be used to avoid damage to windows during and after installation. Prior to installation, store windows in a near vertical position with adequate sill support, in a clean area free of circulating dirt or debris and protected from exposure to weather elements.

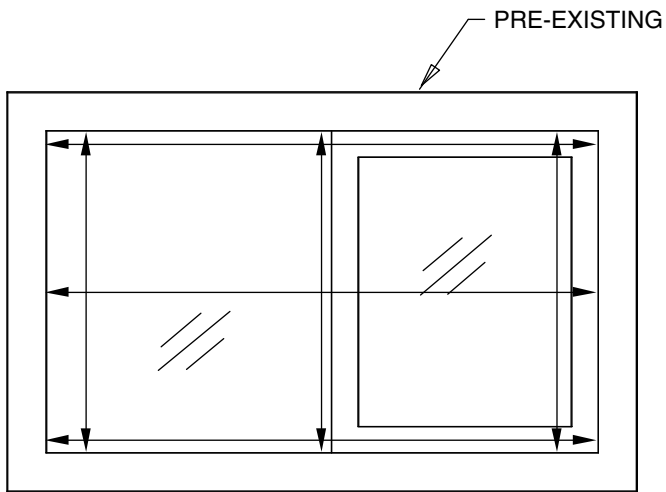

Figure 1 MEASURE HORIZONTALLY AND VERTICALLY AT THREE POINTS AND RECORD SMALLEST DAYLIGHT OPENING DIMENSIONS.

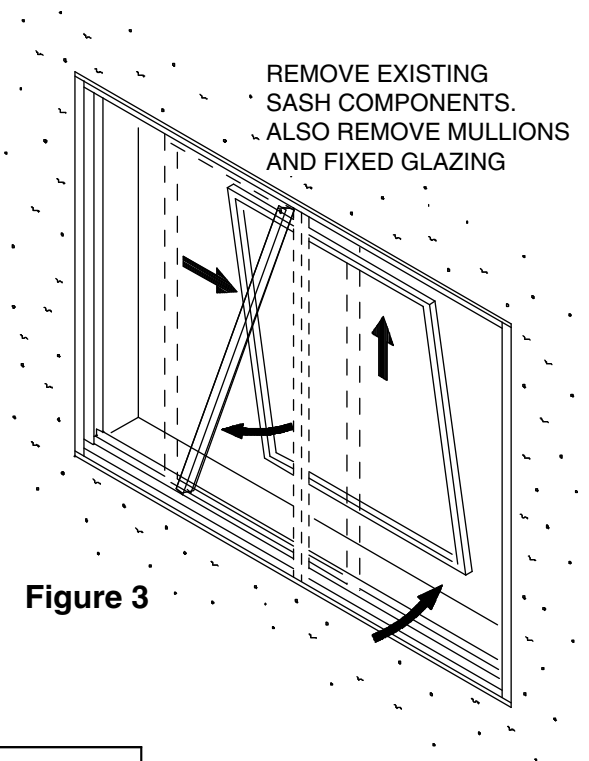
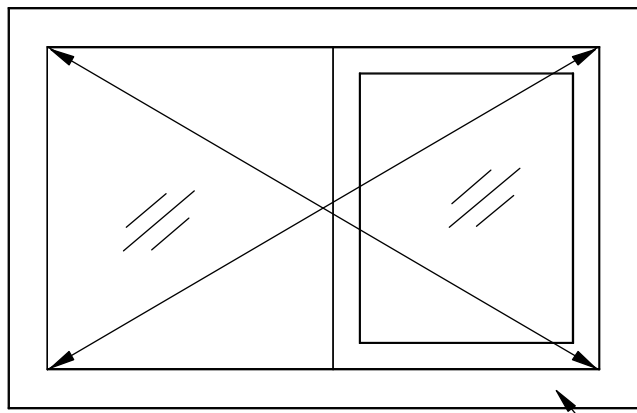
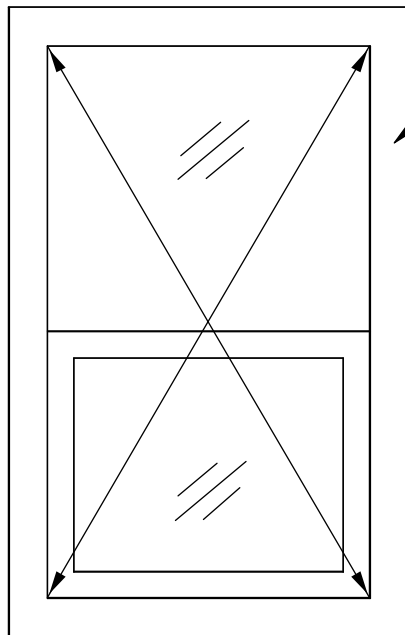

Figure 3



MEASURE DIAGONALLY



PRE-EXISTING FRAME

Figure 2

BLOCKING AS NECESSARY TO PREVENT ROTATION OF NEW WINDOW SILL

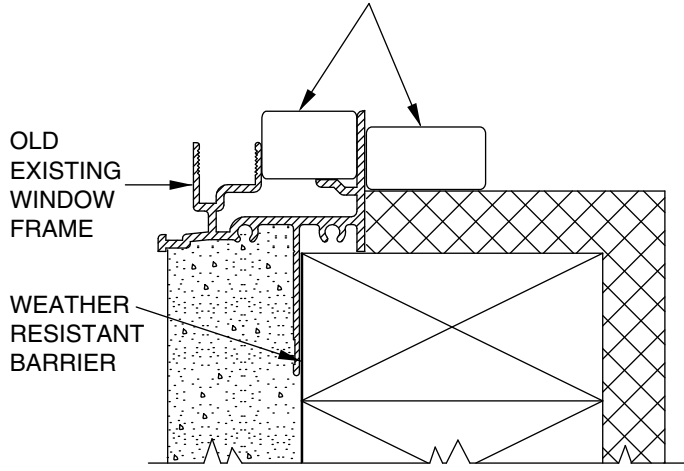
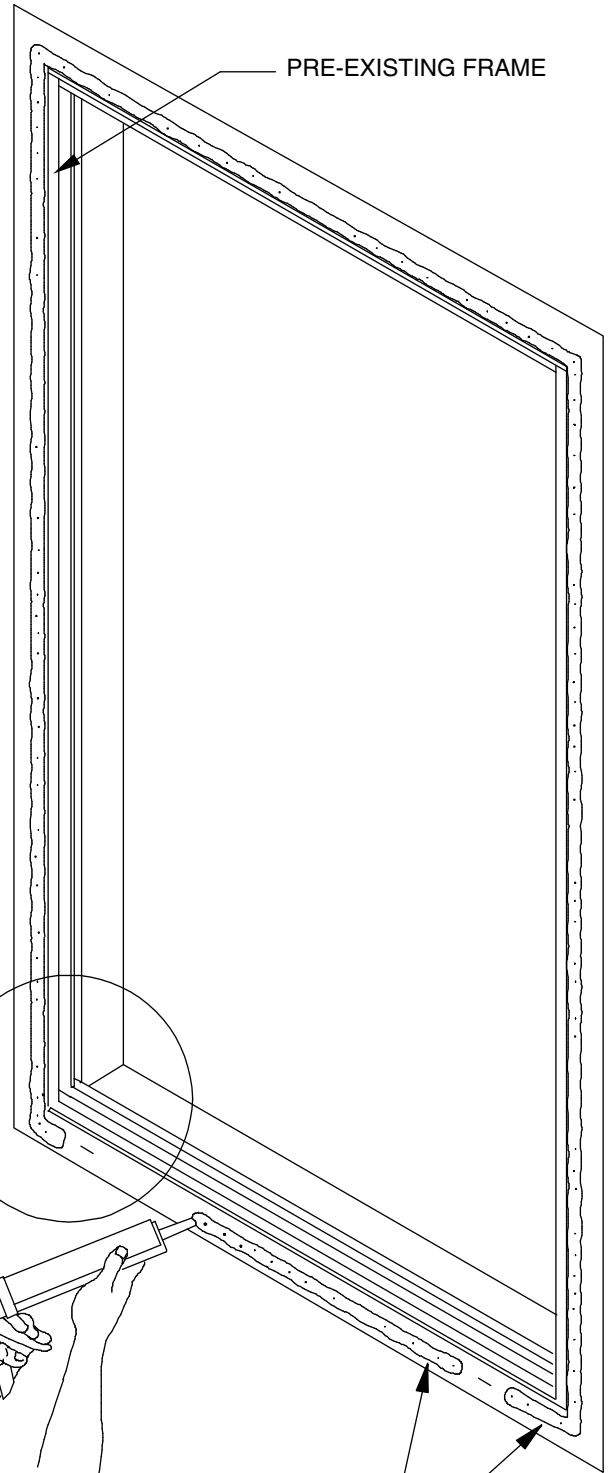
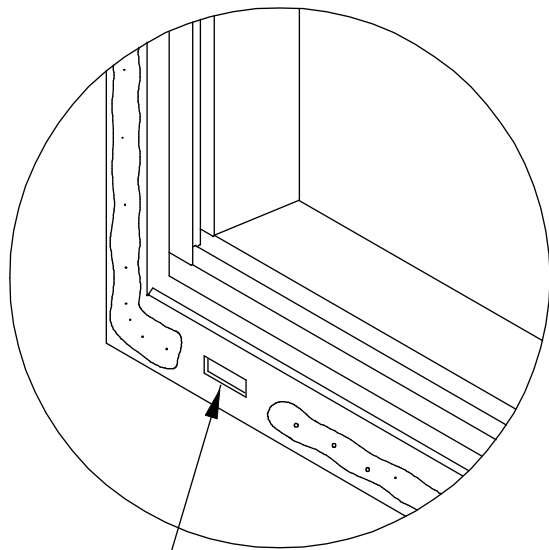
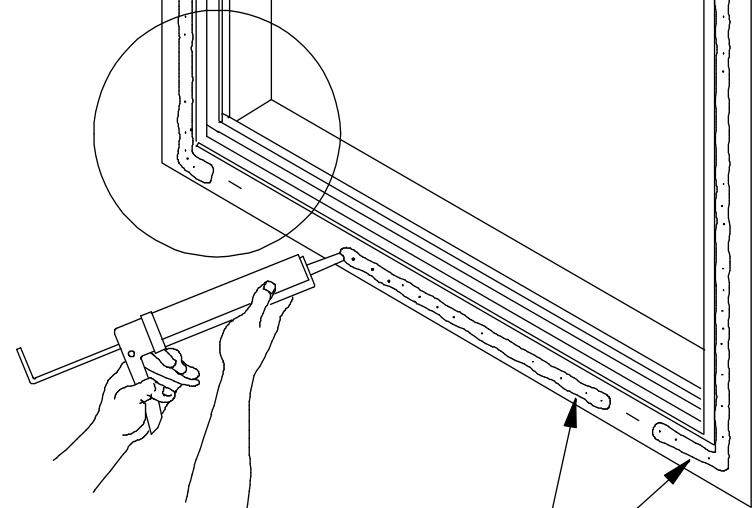

Figure 4

(SILL CONDITION)



PRE-EXISTING FRAME



DO NOT APPLY SEALANT OVER EXISTING FRAME'S WEEP HOLES

Figure 6

Figure 5

APPLY SEALANT TO MOUNTING SURFACES OF PRE-EXISTING

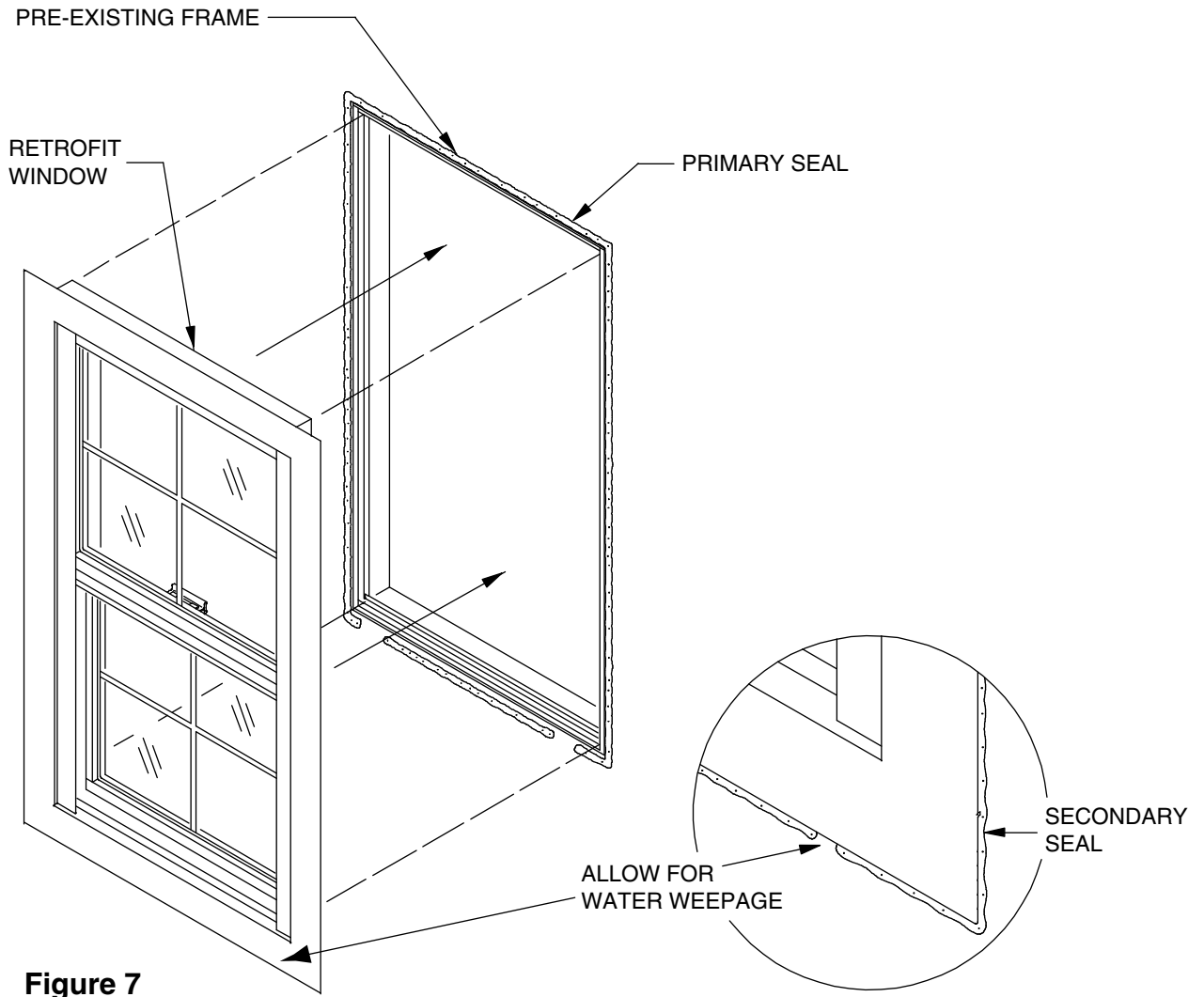

Figure 7

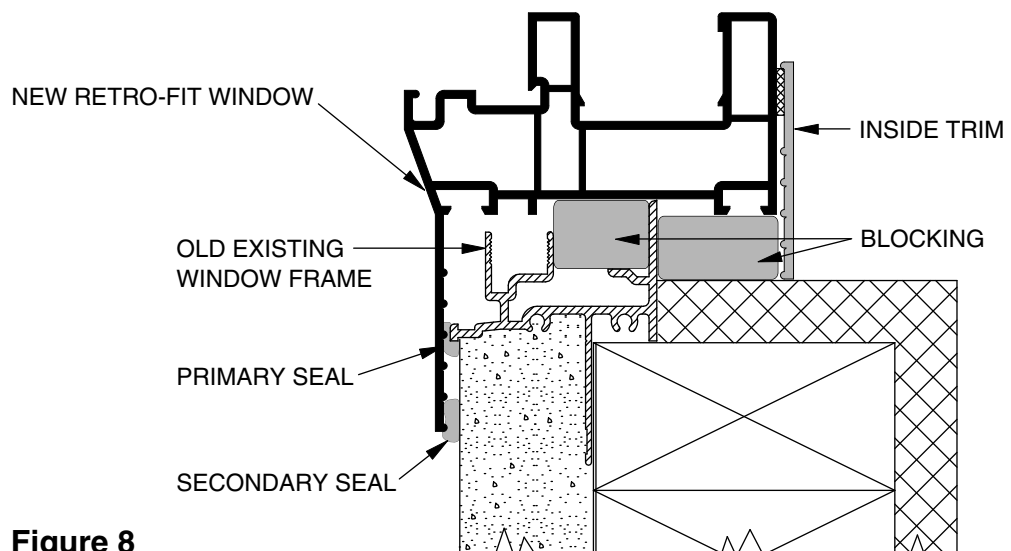

Figure 8



American Architectural Manufacturers Association

1827 Walden Office Square, Suite 550

Schaumburg, IL 60173

PHONE (847) 303-5664 FAX (847) 303-5774

WEBSITE www.aamanet.org

EMAIL webmaster@aamanet.org