

Tri-Max™ 3-Flow Showerhead

FEATURES AND BENEFITS

N2615



Also Available in White

Large POM Swivel Adjustment

Three Flow Rates



Large Conical Spray Pattern



Constant Output Regardless of Pressure

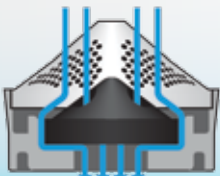

Low Water Pressure

High Water Pressure

Finishes & Flow Rates

	0.5/1.0/1.5 GPM
Chrome	N2615CH
White	N2615

Tri-Max™ 3-Flow Showerhead

Water Savings Without Sacrificing Performance

Extra Power and Full Coverage

- Select Your Savings: 3-pressure compensated flow rate options, 0.5 GPM/1.0 GPM/1.5 GPM
- Niagara's patented pressure compensating technology guarantees a consistent flow rate across wide range of pressure
- Easy grip turn-dial for selecting your savings
- Multi-motion flow with wide to concentrated spray
- Corrosion resistant high-impact ABS thermoplastic body
- Installs easily, by hand and without tools
- Large POM swivel adjustment, lead free
- Limited Lifetime Warranty**

POTENTIAL ANNUAL SAVINGS*

	Water (Gallons)	Electric (kWh)	Gas (therms)	Dollars
Water Savings	16,425			\$131
Energy Savings with Electric Water Heater		2,408		\$320
Energy Savings with Gas Water Heater			82	\$78

*Factors in calculating savings potential:

- 3-person households each using a shower 10 minutes per day, 365 days per year
- Comparing water use with this 1.0 GPM showerhead vs. a standard 2.5 GPM unit
- Water and sewer cost of \$8 per 1,000 gallons
- 8.34 BTUs to raise the temperature of 1 gallon of water 1°
- 500.4 BTUs to raise the temperature of 1 gallon 60° (i.e. 50° to 110°)
- 1 million BTUs = 293 kWh
- Average cost of electricity \$0.133 per kWh (Bureau of Labor Statistics Sept 2012)
- Average cost of gas \$0.953 per therm (Bureau of Labor Statistics Sept 2012)
- On multi-flow rate heads, savings calculated using the avg of available flow rates

Corporate HQ

4200 Diplomacy Road
Fort Worth, TX 76155 USA
Toll Free: 800.831.8383
Phone: 817.391.0800 Fax: 817.391.0801
Email: info@nccgreen.com



Tri-Max™ 3-Flow Showerhead

SPECIFICATIONS

N2615

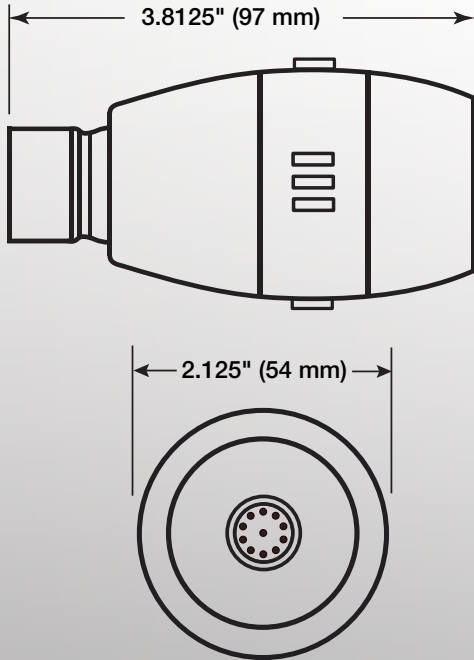

*Dimensions are subject to change

Overall Dimensions	Width 2.125" Height 2.125" Depth 3.8125"
Materials	Corrosion resistant high-impact ABS thermoplastic body; Internal component: ABS and POM plastic & high heat rubber gaskets.
Threads	Inlet size: 1/2-14 NPSM female straight pipe thread
Certifications	Meets or exceeds: ASME A112.18.1/CSA B125.1: ASTM B368 WaterSense labeled - Max. Flow Rate: 1.5 GPM Min. Flow Rate at 45 PSI: 1.13 GPM (4.3 LPM)



0.5 / 1.0 / 1.5 GPM Flow Rate

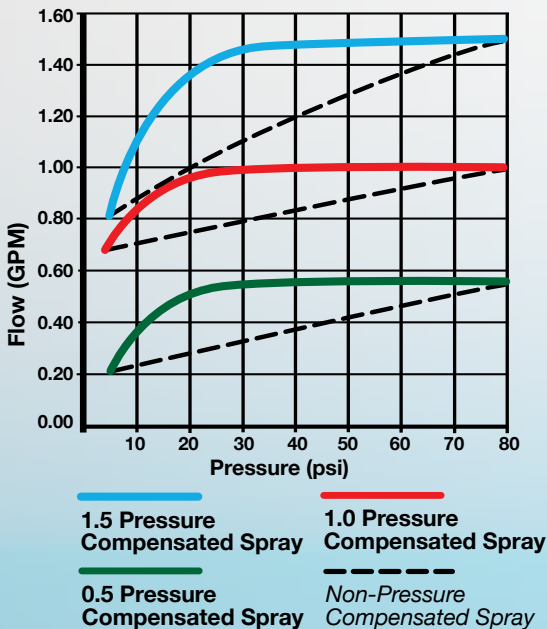

**WARRANTY FOR SHOWERHEADS PURCHASED AT RETAIL:

Limited Lifetime Warranty for showerheads purchased at retail for as long as the original purchaser owns the product. Niagara will replace any part that, in our opinion has proved defective, provided it has not been abused, misused, altered or damaged after its purchase. For complete product warranty details, call Niagara Conservation at 1-800-831-0800.

WARRANTY FOR SHOWERHEADS OBTAINED THROUGH WHOLESALE, MUNICIPALITIES, UTILITIES OR OTHER COMMERCIAL CHANNELS:

10-year Limited Warranty to the purchaser from the date of purchase. Niagara will replace any part that, in our opinion has proved defective, provided it has not been abused, misused, altered or damaged after its purchase. For complete product warranty details, call Niagara Conservation at 1-800-831-0800.

Corporate HQ

4200 Diplomacy Road
Fort Worth, TX 76155 USA
Toll Free: 800.831.8383
Phone: 817.391.0800 Fax: 817.391.0801
Email: info@nccgreen.com



Tri-Max™ 3-Flow Showerhead

N2615CH

Retail Packaging:

Blistercard Display Packaging



Retail Displaying:
Shipping and Displaying Tray

RETAIL PACKAGING

Item No	RN2615CH
UPC Code	732291000055
Type of Packaging	Blistercard Display Packaging
Pack Quantities	6 Blistercards in Tray and RSC Master Carton
Dimensions Ea. Pkg.	Height 8.5" Width 5.75" Depth 2.5"
Weight Ea. Pkg.	0.32 lbs
I205 Master	10732291000052
Dimensions of Master	Height 7.25" Width 16.5" Depth 8.875"
Weight of Master	3.5 lbs

Bulk Packaging:

Bubblewrap Bag



BULK PACKAGING

Item No	N2615CH	N2615
UPC Code	732291261517	732291261029
Type of Packaging	Kraft Corrugated	
Pack Quantities	100 Per Carton	
Dimensions of Master	Height 12.25" Width 11.75" Depth 23"	
Weight of Master	28.45 lbs	

Corporate HQ

4200 Diplomacy Road
Fort Worth, TX 76155 USA
Toll Free: 800.831.8383
Phone: 817.391.0800 Fax: 817.391.0801
Email: info@nccgreen.com

